

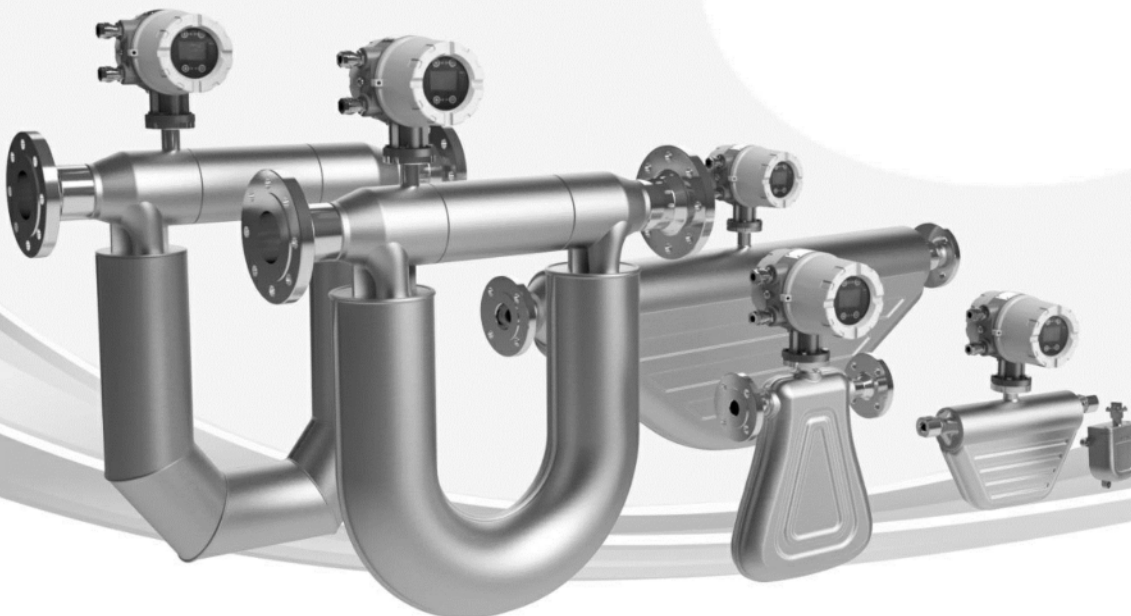



Coriolis Massflowmeter

Klinger CMF type V and U Instruction Manual



Safety Related Symbol Description

The following symbols are used for security related content in this guide. Statements marked with security symbols are important contents, please be sure to follow.



 DANGER	<p>An error occurring in the use of the described content may be dangerous and may result in personal injury or death.</p>
 CAUTION	<p>An error occurring in the use of the content may be dangerous and may result in a person with mild or moderate damage or damage to the device. But, the symbol is a matter of attention; major accidents may be caused due to the different circumstances.</p>
 IMPORTANT	<p>Certain matters do not belong to the scope of “Danger”, “Caution”, however, the matters users needing to comply with are also marked in the relevant section.</p>
 FORBIDDEN	<p>Prohibited matters, if not complying with, it may affect the use performance or safety performance of the instrument.</p>

Priorities



□ open-package inspection

 CAUTION	<ul style="list-style-type: none"> □ Do not use the mass flow meter with damaged or missing parts. □ There is a risk of internal injuries.
--	--

□ wiring

 DANGER	<ul style="list-style-type: none"> □ Please confirm that the power is off before wiring. □ There is a risk of electric shock, fire or explosion.
 CAUTION	<ul style="list-style-type: none"> □ Please make the power supply is consistent with the transmitter. □ There is a risk of injury fire or explosion. □ Site voltage and insulation test is forbidden! □ It may cause damages to such devices as semiconductors, capacitors and coils.

□ Application

 CAUTION	<ul style="list-style-type: none"> □ Please do not use it in direct sunlight places. □ There is a risk of aging cable, damaging LCD panel. □ It is inconvenient to observe the display contents of the LCD panel.
 IMPORTANT	<ul style="list-style-type: none"> □ Please read this guide carefully before use. □ There is a risk of damage to the instrument.

Content

Chapter I	Introduction	Page 5
Chapter II	Installation	Page 7
Chapter III	Wiring	Page 21
Chapter IV	Initial Start-up	Page 25
Chapter V	Software Operation Guide	Page 27
Chapter VI	Communication	Page 48
Chapter VII	Troubleshooting	Page 61
Chapter VIII	Daily Care and Maintenance	Page 68



Chapter | Introduction

1.1 Profile

The Klinger mass flowmeter is composed of two parts, the sensor and the transmitter. The Klinger mass flow meter is equipped with a digital transfer device, which is based on a digital signal processor (DSP), integrated with digital close-loop vibration controlling (DLC) signal processing, calculating and diagnostic functions of sensor, and provides high measuring accuracy, wide range ability and excellent reliability for you. Online node-configuration, faults diagnosis and data recording can be carried out directly through communication with a communicator by HART or by PC through Modbus.

The flow meter will not only calculate process volume flow rate, accumulated volume and component proportion. The TS Series flowmeter can also provide mass flow rate, density and temperature online and in real-time.

The Klinger mass flowmeter sensor is divided into two series: US and VS.



Figure 1-12 US series integral mass flowmeter, with T1, T2 and T3 transmitters



Figure 1-13 US series remote mass flowmeter sensor, with T1, T2 and T3 transmitters



Figure 1-14 remote mass flowmeter transmitter, T1, T2 and T3

1.3.1.3 Flowmeter sensor, DN1-DN5

See figure 1-15



Figure 1-15 US series remote mass flowmeter sensor, DN1-DN5

1.4 VS series

New generation of product with twinned micro bend flow tubes.

1.4.1 Figure

See figure 1-18, 1-19, and 1-20

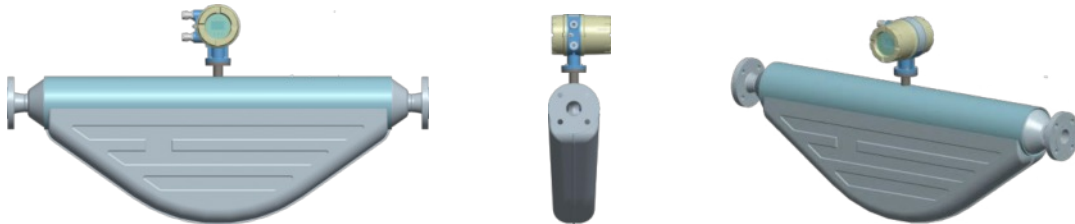

Figure 1-18 VS series integral mass flowmeter



Figure 1-19 VS series remote mass flowmeter sensor

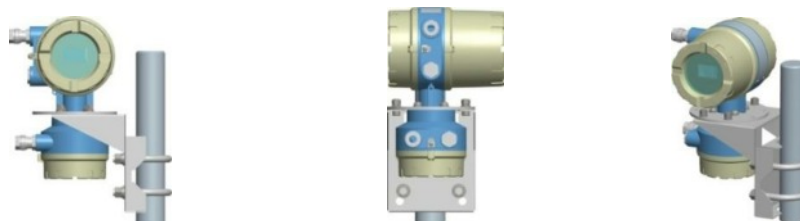

Figure 1-14 remote mass flowmeter transmitter

Chapter II Installation

2.1 Preparation before installation

2.1.1 Environmental consideration

The SCM must be appropriately configured for its installation environment. Exposing the CMF to an unapproved environment can reduce the lifespan of the instrument, void warranty and/or liability statements, and is dangerous. To confirm that the CMF is configured for the installation environment:



2.1.1.1 Ensure the explosion-proof certification marks on the nameplates meet or exceed the required rating of the relevant installation environment.

2.1.1.2 Ensure that the enclosure rating indicated on the nameplates meet the requirements of the installation environment.

2.1.1.3 Ensure that the ambient and process temperature ranges indicated on the nameplates meet the application requirements.

See details in Figure 2-1

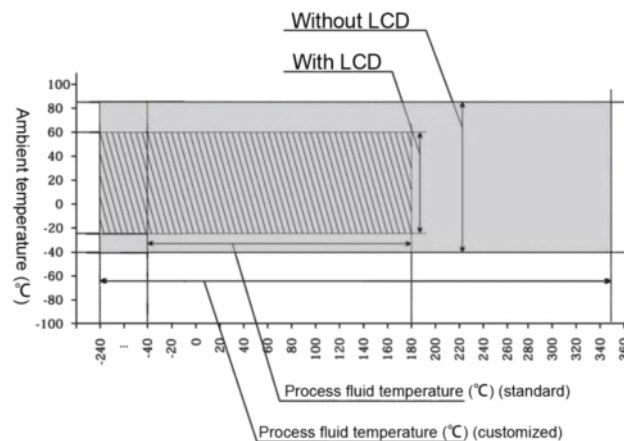

Figure 2-1 mass flowmeter temperature range

2.1.2 Mechanical Factors

The location and orientation of the SCM can have a large impact on its accuracy, ease of use, and ease of maintenance.

2.1.2.1 Enough Installation Space

Meet the needs of installation, maintenance and observation.

2.1.3 Product Status

2.1.3.1 Integrated product has no wiring of sensor and transmitter.

2.1.3.2 Special cable for Walsn mass flow meter allocated for Remote product (Ensure length to meet the installation and use requirements).

2.1.4 Installation location

2.1.4.1 Sensor

Ideal installation location will get the best product performance

Consider the following criteria when choosing the location of the

SCM 2.1.4.1.1 Away from sources of electromagnetic interference



2.1.4.1.1.1 The installation position of the sensor and transmitter should be far away from industrial sources of electromagnetic interference, such as high power motors, transformers, etc., otherwise, the simple harmonic vibration of the flow tube of sensor will be subject to interference, a weak signal detected by the coil may be submerged in the noise of electromagnetic interference. Sensor and transmitter should maintain a sufficient distance with the transformer, motor, etc., specific details please consult the manufacturer or local dealer.

2.1.4.1.1.2 Electromagnetic interference (EMI) from sources such as high power motors, transformers, etc. can interfere with the precision coils that drive the SCM and the signal generated by the EMI. Sensors, transmitters, and their cables should be installed at least 5m away from large sources of EMI.

2.1.4.1.2 Away from sources of vibration

2.1.4.1.2.1 Sensor installation location should maintain enough distance with the interference source of mechanical vibration in process pipeline (i.e. pump), specific details please consult the manufacturer or local dealer.

2.1.4.1.2.2 If multiple sensors are used in series on the same process pipeline, the cross influence by resonance must be prevented, by ensuring the distance between each sensor is at least 3 times the size of the flange face to face.

2.1.4.1.3 Away from expansion joints

Compressive or tensile loads on the sensor can interfere with the CMF's accuracy. The SCM should be located away from any point where longitudinal forces are likely to act on the sensor (e.g. due to thermal expansion & contraction).

2.1.4.2 Transmitter

2.1.4.2.1 Environmental requirements

Relative humidity: 5%RH-95%RH

Temperature: see figure 2-1

2.1.4.2.2 Power Supply

Ensure that the power available at the transmitter's installation location is compatible with the power supply indicated on the transmitter's nameplate.

DC: 18 VDC-36VDC

AC: 85 VAC-265VAC, 50/60Hz

Self switching: 18VDC-36VDC or 85VAC-265VAC, 50/60Hz

2.1.4.2.3 Power consumption ≤ 20W

2.1.4.2.4 Remote cable length: 5m-100m.

For remote mount transmitters, the transmitter must be connected to the sensor on-site. Ensure that there is adequate cable length to safely and tidily route the cable from the sensor location to the desired transmitter location. Use only cable provided by Walsn.

2.1.4.2.5 Visible

The transmitter should be placed such that the LCD is in a position and orientation that is easy to observe.

2.1.4.2.6 Maintainable

There should be enough space for transmitter cover removing & wiring.

2.2 Installation



Dimensions

2.2.1.1.2 T1, T2 and T3 transmitters size, in(mm)

See figure 2-4, 2-5

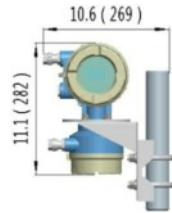

Figure 2-4

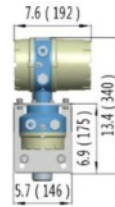

Figure 2-5

2.2.1.3 US series

2.2.1.3.1 Integral mass flowmeter with T0 transmitter

See figure 2-14, 2-15



Figure 2-14

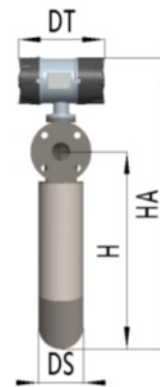

Figure 2-15

2.2.1.3.1.1 Imperial size, in

See table 2-9

Table 2-9

Specification	Line Size	L	H	HA	DS	DT
SCM-US-010N	3/8	7-7/8	6-11/16	16-7/16	2-3/8	9-7/16
SCM-US-015N	1/2	10-1/16	8-11/16	19-1/16	2-9/16	9-7/16
SCM-US-025N	1	12	12-3/16	21-5/8	2-13/16	9-7/16
SCM-US-040N	1-1/2	22-5/8	20-9/16	30-9/16	4-3/4	9-7/16
SCM-US-040H	1-1/2	24-1/2	21-3/8	31-15/32	4-3/4	9-7/16
SCM-US-050N	2	24-1/2	21-3/8	31-15/32	4-3/4	9-7/16
SCM-US-050H	2	27-21/32	25-15/16	36-5/32	5-29/32	9-7/16
SCM-US-080N	3	30-1/16	26-11/16	37-7/16	5-29/32	9-7/16

SCM-US-080H	3	33-7/16	33-7/8	45-5/8	7-23/32	9-7/16
SCM-US-100N	4	32-1/4	28-29/32	40-7/16	5-29/32	9-7/16
SCM-US-100H	4	41-29/32	45-9/32	57-31/32	11-29/32	9-7/16
SCM-US-150N	6	45-11/16	39-1/8	51-11/16	9-21/32	9-7/16
SCM-US-150H	6	40-5/16	49-1/2	63-3/8	12-27/32	9-7/16
SCM-US-200N	8	49-15/16	49-1/2	64-15/16	12-27/32	9-7/16
SCM-US-250N	10	69-5/16	68-15/16	84-5/8	17-1/8	9-7/16

2.2.1.3.1.2 Metric size, mm
See table 2-10

Table 2-10

Specification	Line Size	L	H	HA	DS	DT
SCM-US-010N	10	200	170	418	95	240
SCM-US-015N	15	256	220	485	115	240
SCM-US-025N	25	304	310	550	135	240
SCM-US-040N	40	574	522	776	121	240
SCM-US-040H	40	622	542	799	121	240
SCM-US-050N	50	622	542	799	121	240
SCM-US-050H	50	702	658	918	150	240
SCM-US-080N	80	763	678	951	150	240
SCM-US-080H	80	850	861	1159	196	240
SCM-US-100N	100	822	733	1027	150	240
SCM-US-100H	100	1064	1150	1472	302	240
SCM-US-150N	150	1160	994	1313	245	240
SCM-US-150H	150	1240	1257	1609	326	240
SCM-US-200N	200	1268	1257	1609	326	240
SCM-US-250N	250	1760	1751	2150	435	240

2.2.1.3.2 Integral mass flowmeter with T1, T2 and T3 transmitters
See table 2-16, 2-17



Figure 2-16

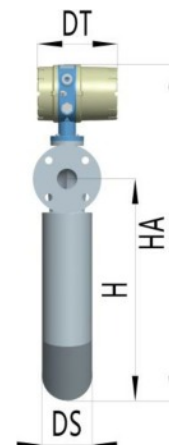

Figure 2-17

2.2.1.3.2.1 Imperial size, in
See table 2-11

Table 2-11

Specification	Line Size	L	H	HA	DS	DT
SCM-US-010N	3/8	7-7/8	6-11/16	17-1/8	2-3/8	7-9/16
SCM-US-015N	1/2	10-1/16	8-11/16	19-3/4	2-9/16	7-9/16
SCM-US-025N	1	12	12-3/16	22-3/8	2-13/16	7-9/16
SCM-US-040N	1-1/2	22-5/8	20-9/16	31-9/32	4-3/4	7-9/16
SCM-US-040H	1-1/2	24-1/2	21-3/8	32-7/32	4-3/4	7-9/16
SCM-US-050N	2	24-1/2	21-3/8	32-7/32	4-3/4	7-9/16
SCM-US-050H	2	27-21/32	25-15/16	36-27/32	5-29/32	7-9/16
SCM-US-080N	3	30-1/16	26-11/16	38-5/32	5-29/32	7-9/16
SCM-US-080H	3	33-7/16	33-7/8	46-11/32	7-23/32	7-9/16
SCM-US-100N	4	32-1/4	28-29/32	41-5/32	5-29/32	7-9/16
SCM-US-100H	4	41-29/32	45-9/32	58-21/32	11-29/32	7-9/16
SCM-US-150N	6	45-11/16	39-1/8	52-13/32	9-21/32	7-9/16
SCM-US-150H	6	40-5/16	49-1/2	64-9/16	12-27/32	7-9/16
SCM-US-200N	8	49-15/16	49-1/2	64-9/16	12-27/32	7-9/16
SCM-US-250N	10	69-5/16	68-15/16	853/8	17-1/8	7-9/16

2.2.1.3.2.2 Metric size, mm
See table 2-12

Table 2-12

Specification	Line Size	L	H	HA	DS	DT
SCM-US-010N	10	200	170	436	95	192
SCM-US-015N	15	256	220	503	115	192
SCM-US-025N	25	304	310	568	135	192
SCM-US-040N	40	574	522	794	121	192
SCM-US-040H	40	622	542	817	121	192
SCM-US-050N	50	622	542	817	121	192
SCM-US-050H	50	702	658	936	150	192
SCM-US-080N	80	763	678	969	150	192
SCM-US-080H	80	850	861	1177	196	192
SCM-US-100N	100	822	733	1045	150	192
SCM-US-100H	100	1064	1150	1490	302	192
SCM-US-150N	150	1160	994	1331	245	192
SCM-US-150H	150	1240	1257	1627	326	192
SCM-US-200N	200	1268	1257	1627	326	192
SCM-US-250N	250	1760	1751	2168	435	192

2.2.1.3.3 Remote mass flowmeter with T0 transmitter

See figure 2-18, 2-19, 2-20, and 2-21



Figure 2-18

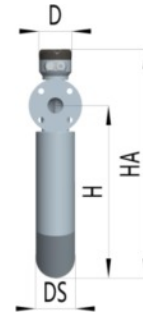

Figure 2-19



Figure 2-20

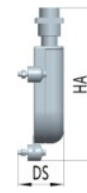

Figure 2-21

2.2.1.3.3.1 Imperial size, in

See table 2-13

Table 2-13

Specification	Line Size	L	H	HA	DS	D
SCM-US-001N	1/24	4-1/2	\	5-7/8	1-3/16	\
SCM-US-002N	1/12	5-5/16	\	6-11/16	1-9/16	\
SCM-US-005N	3/16	6-7/8	\	8-1/4	2-9/16	\
SCM-US-010N	3/8	7-7/8	6-11/16	9-1/2	2-3/8	3-15/16
SCM-US-015N	1/2	10-1/16	8-11/16	14-5/8	2-9/16	3-15/16
SCM-US-025N	1	12	12-3/16	18-3/8	2-13/16	3-15/16
SCM-US-040N	1-1/2	22-5/8	20-9/16	30-9/16	4-3/4	3-15/16
SCM-US-040H	1-1/2	24-1/2	21-3/8	31-15/32	4-3/4	3-15/16
SCM-US-050N	2	24-1/2	21-3/8	31-15/32	4-3/4	3-15/16
SCM-US-050H	2	27-21/32	25-15/16	36-5/32	5-29/32	3-15/16
SCM-US-080N	3	30-1/16	26-11/16	37-7/16	5-29/32	3-15/16
SCM-US-080H	3	33-7/16	33-7/8	45-5/8	7-23/32	3-15/16
SCM-US-100N	4	32-1/4	28-29/32	40-7/16	5-29/32	3-15/16
SCM-US-100H	4	41-29/32	45-9/32	57-31/32	11-29/32	3-15/16
SCM-US-150N	6	45-11/16	39-1/8	51-11/16	9-21/32	3-15/16
SCM-US-150H	6	40-5/16	49-1/2	63-3/8	12-27/32	3-15/16
SCM-US-200N	8	49-15/16	49-1/2	64-15/16	12-27/32	3-15/16
SCM-US-250N	10	69-5/16	68-15/16	81-7/16	17-1/8	3-15/16

2.2.1.3.3.2 Metric size, mm
See table 2-14

Table 2-14

Specification	Line Size	L	H	HA	DS	D
SCM-US-001N	1	115	\	149	30	\
SCM-US-002N	2	135	\	169	40	\
SCM-US-005N	5	175	\	209	65	\
SCM-US-010N	10	200	170	241	95	100
SCM-US-015N	15	256	220	372	115	100
SCM-US-025N	25	304	310	467	135	100
SCM-US-040N	40	574	522	694	121	100
SCM-US-040H	40	622	542	717	121	100
SCM-US-050N	50	622	542	717	121	100
SCM-US-050H	50	702	658	836	150	100
SCM-US-080N	80	763	678	869	150	100
SCM-US-080H	80	850	861	1077	196	100
SCM-US-100N	100	822	733	945	150	100
SCM-US-100H	100	1064	1150	1390	302	100
SCM-US-150N	150	1160	994	1231	245	100
SCM-US-150H	150	1240	1257	1527	326	100
SCM-US-200N	200	1268	1257	1527	326	100
SCM-US-250N	250	1760	1751	2068	435	100

2.2.1.3.4 Remote mass flowmeter with T1, T2 and T3 transmitters
See figure 2-22, 2-23, 2-24, and 2-25



Figure 2-22

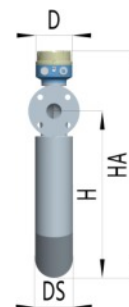

Figure 2-23



Figure 2-24

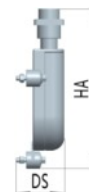

Figure 2-25

2.2.1.3.4.1 Imperial size, in
See table 2-15

Table 2-15

Specification	Line Size	L	H	HA	DS	D
SCM-US-001N	1/24	4-1/2	\	5-7/8	1-3/16	\
SCM-US-002N	1/12	5-5/16	\	6-11/16	1-9/16	\
SCM-US-005N	3/16	6-7/8	\	8-1/4	2-9/16	\
SCM-US-010N	3/8	7-7/8	6-11/16	10-3/16	2-3/8	4-5/8
SCM-US-015N	1/2	10-1/16	8-11/16	15-3/8	2-9/16	4-5/8
SCM-US-025N	1	12	12-3/16	19-1/16	2-13/16	4-5/8
SCM-US-040N	1-1/2	22-5/8	20-9/16	28-1/32	4-3/4	4-5/8
SCM-US-040H	1-1/2	24-1/2	21-3/8	28-15/16	4-3/4	4-5/8
SCM-US-050N	2	24-1/2	21-3/8	28-15/16	4-3/4	4-5/8
SCM-US-050H	2	27-21/32	25-15/16	33-5/8	5-29/32	4-5/8
SCM-US-080N	3	30-1/16	26-11/16	34-15/16	5-29/32	4-5/8
SCM-US-080H	3	33-7/16	33-7/8	43-1/8	7-23/32	4-5/8
SCM-US-100N	4	32-1/4	28-29/32	36-27/32	5-29/32	4-5/8
SCM-US-100H	4	41-29/32	45-9/32	55-7/16	11-29/32	4-5/8
SCM-US-150N	6	45-11/16	39-1/8	49-3/16	9-21/32	4-5/8
SCM-US-150H	6	40-5/16	49-1/2	60-13/16	12-27/32	4-5/8
SCM-US-200N	8	49-15/16	49-1/2	60-13/16	12-27/32	4-5/8
SCM-US-250N	10	69-5/16	68-15/16	82-1/8	17-1/8	4-5/8

2.2.1.3.4.2 Metric size, mm
See table 2-16

Table 2-16

Specification	Line Size	L	H	HA	DS	D
SCM-US-001N	1	115	\	149	30	\
SCM-US-002N	2	135	\	169	40	\
SCM-US-005N	5	175	\	209	65	\
SCM-US-010N	10	200	170	259	95	117
SCM-US-015N	15	256	220	390	115	117
SCM-US-025N	25	304	310	485	135	117
SCM-US-040N	40	574	522	712	121	117
SCM-US-040H	40	622	542	735	121	117
SCM-US-050N	50	622	542	735	121	117
SCM-US-050H	50	702	658	854	150	117
SCM-US-080N	80	763	678	887	150	117

SCM-US-080H	80	850	861	1095	196	117
SCM-US-100N	100	822	733	963	150	117
SCM-US-100H	100	1064	1150	1408	302	117
SCM-US-150N	150	1160	994	1249	245	117
SCM-US-150H	150	1240	1257	1545	326	117
SCM-US-200N	200	1268	1257	1545	326	117
SCM-US-250N	250	1760	1751	2086	435	117

2.2.1.4 VS series

2.2.1.4.1 Integral mass flowmeter with T1, T2 and T3 transmitters

See figure 2-26, 2-27

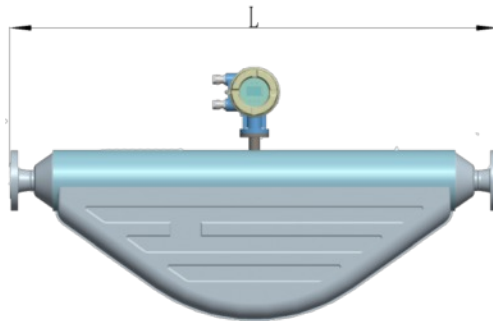

Figure 2-26

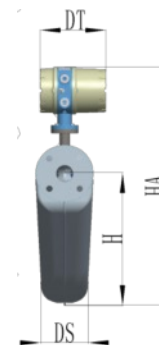

Figure 2-27

2.2.1.4.1.1 Imperial size, in

See table 2-17

Table 2-17

Specification	Line Size	L	H	HA	DS	DT
SCM-VS-005	3/16	14-1/2	4-1/16	13-7/8	1-15/16	7-9/16
SCM-VS-015	1/2	17-1/2	7-1/2	17-4/5	3-1/2	7-9/16
SCM-VS-025	1	17-1/2	7-1/2	17-4/5	3-1/2	7-9/16
SCM-VS-040	1-1/2	29	11-1/4	24-5/16	4-3/4	7-9/16
SCM-VS-050	2	29	11-1/4	24-5/16	4-3/4	7-9/16
SCM-VS-080	3	52-9/16	15-3-16	18-1/4	6-5/8	7-9/16

2.2.1.4.1.2 Metric size, mm

See table 2-18

Table 2-18

Specification	Line Size	L	H	HA	DS	DT
SCM-VS-005	5	368	103	352	49	192
SCM-VS-015	15	444	190	452	89	192
SCM-VS-025	25	444	190	452	89	192
SCM-VS-040	40	735	286	617	120	192
SCM-VS-050	50	735	286	617	120	192
SCM-VS-080	80	1336	386	717	168	192

2.2.1.4.2 Remote mass flowmeter with T1, T2 and T3 transmitters
See figure 2-28, 2-29

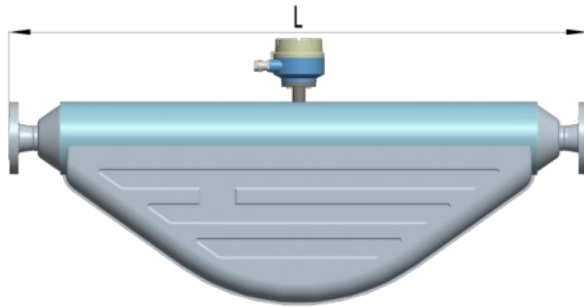

Figure 2-28

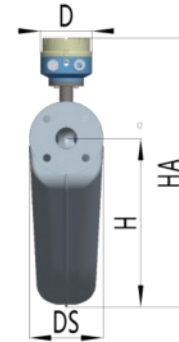

Figure 2-29

2.2.1.4.2.1 Imperial size, in
See table 2-19

Table 2-19

Specification	Line Size	L	H	HA	DS	D
SCM-VS-005	3/16	14-1/2	4-1/16	10-5/8	1-15/16	4-5/8
SCM-VS-015	1/2	17-1/2	7-1/2	14-9/16	3-1/2	4-5/8
SCM-VS-025	1	17-1/2	7-1/2	14-9/16	3-1/2	4-5/8
SCM-VS-040	1-1/2	29	11-1/4	21-1/16	4-3/4	4-5/8
SCM-VS-050	2	29	11-1/4	21-1/16	4-3/4	4-5/8
SCM-VS-080	3	52-9/16	15-3-16	25	6-5/8	4-5/8

2.2.1.4.2.2 Metric size, mm
See table 2-20

Table 2-20

Specification	Line Size	L	H	HA	DS	D
SCM-VS-005	5	368	103	270	49	117
SCM-VS-015	15	444	190	370	89	117
SCM-VS-025	25	444	190	370	89	117
SCM-VS-040	40	735	286	535	120	117
SCM-VS-050	50	735	286	535	120	117
SCM-VS-080	80	1336	386	635	168	117

2.2.2 Sensor Installation

2.2.2.1 Sensor Orientation

Sensor orientation can have a significant effect on the performance of the SCM. In general the orientation should be chosen to ensure the flow tube is always filled with the process fluid and to prevent accumulation of other media.

2.2.2.1.1 Upright installation (Figure 2-34)



Figure 2-34

2.2.2.1.1.1 Upright installation (as shown in Figure 2-34) is generally preferred if the process fluid is a liquid, and the process fluid is easily vaporized. Upright installation prevents the accumulation of vapor or air in the sensor tubes.

2.2.2.1.2 Inverted installation (Figure 2-35)



Figure 2-35

2.2.2.1.2.1 Inverted installation (as shown in Figure 2-35) is preferred if the process fluid is a liquid with entrained solids, or if the process fluid is a gas which may condense. Inverted installation prevents higher density media from accumulating in the sensor tubes.

2.2.2.1.3 Flagpole installation (Figure 2-36)



Figure 2-36

2.2.2.1.3.1 Flagpole installation (as shown in Figure 2-36) is a compromise. It may be preferred if the process fluid is a slurry mixture, or if the pipe is to be purged with gas or steam.

2.2.2.1.3.2 It is more difficult to fix than upright and inverted installation.

2.2.2.2 Typical installation

2.2.2.2.1 Normal line size: DN10~DN250(Figure 2-37)

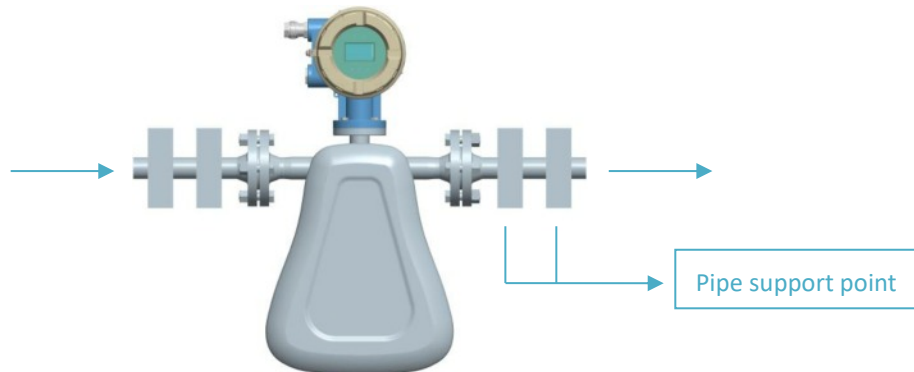

Figure 2-37

2.2.2.2.2 Small line size:DN1~DN5(Figure 2-38, 2-39, 2-40, 2-41)



Figure 2-38



Figure 2-39



Figure 2-40



Figure 2-41

2.2.2.3 Instructions and precautions

2.2.2.3.1 Upstream and downstream straight pipe

No requirement.

2.2.2.3.2 **Avoiding stress**

2.2.2.3.2.1 Coaxial installation

Sensor flange (or thread) must be coaxial installed with the pipe flange (or thread).

2.2.2.3.2.2 Ensure the housing of sensor is impending, and not in contact with any object

2.2.2.3.2.3 Sensor installation

Install all piping and valves prior to connecting the SCM.

When installing the vertical pipe, the sensor, the valve and the process pipeline should be in the same vertical plane.

2.2.2.3.2.4 When installing the vertical pipe, the sensor, the valve and the process pipeline should be in the same vertical surface.

2.2.2.3.2.5 **Do not at any time apply force to the body of the sensor. Use only the flanges or provided lifting lugs for manipulating the sensor into position.**

2.2.2.3.3 **Vibration isolation**

2.2.2.3.3.1 To prevent vibration solid supports should be securely installed on the pipe on both sides of the sensor.

2.2.2.3.3.2 Pipeline support only supporting process pipeline.

2.2.2.3.3.3 All threaded connections must be tightened.

2.2.2.3.3.4 **Prohibit the use of sensor housing to support process pipeline.**

2.2.2.3.3.5 For small line size sensor, it should be installed on a vertical surface bracket through such flexible connections as rubber gasket, and the installed bracket weight ≥ 10 times the Sensor.

2.2.2.3.4 Valve

2.2.2.3.4.1 To facilitate any future maintenance operations, stop valves should be installed both upstream and downstream of the sensor.

2.2.2.3.4.2 **Ensure that the downstream shutoff valve is closed without leakage.**

2.2.2.3.4.3 **Control valve should be installed downstream of the sensor.**

2.2.2.3.5 Others

2.2.2.3.5.1 New pipe installations should be purged prior to installing the sensor.

2.2.2.3.5.2 The sensor should be removed prior to the welding operations on the pipe.

2.2.2.3.5.3 Note the default forward flow direction indicated on the sensor housing.



2.2.3 Transmitter Installation

2.2.3.1 Installation

2.2.3.1.1 Integrated installation

2.2.3.1.1.1 For the installation of an integrated mass flow meter, there is no special transmitter installation guide.

2.2.3.1.1.2 To enhance visibility the transmitter can be rotated up to 360 degrees in 90 degree increments. (Please confirm the original state before rotating) To do so:

- Loosen and remove the bolts connecting the transmitter and the flange it is mounted to.
- Gently rotate the transmitter to the desired angle.
- Screw the transmitter to its flange.



2.2.3.1.1.3 To enhance visibility the LCD can be rotated up to 270 degrees according in 90 degree increments mode. (Please confirm the original state before rotating) To do so:

- Remove the front cover from the transmitter.
- Loosen and remove the screws securing the LCD to the transmitter.
- Check the LCD connections for pre-existing twist.
- Gently rotate the LCD to the desired angle ensuring that the connections do not become over twisted.
- Re-install and tighten the LCD screws and the front cover.



2.2.3.1.2 Remote installation

2.2.3.1.2.1 Transmitter can be installed in any desired location.

2.2.3.1.2.2 Cable length: 5 m -100 m.



2.2.3.2 Instructions and precautions

2.2.3.2.1 Please do not place the transmitter conduits up along.

2.2.3.2.2 Ensure that the cover of transmitter is fully tightened.

2.2.3.2.3 Ensure that the O-ring is firmly seated and in good condition.

Chapter III Wiring

3.1 Integral SCM wiring

3.1.1 Internal wiring

For SCM with integral transmitters, wiring between sensor & transmitter is complete before it leaves the factory.

3.1.2 T0 Version transmitter

3.1.2.1 The transmitter’s terminal layout is detailed in Figure 3-1, and the terminal functions are defined by Table 3-1. (Analog Loop 2 is not default option)

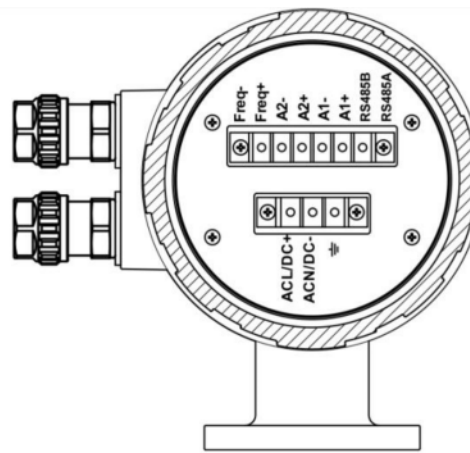



Figure 3-1 T0 version transmitter terminal layout

Table 3-1 T0 version transmitter terminal description

Power Supply	ACL/DC+	Live / Positive	Confirm range against nameplate
	ACN/DC-	Neutral/Negative	
Ground		Ground	
	Freq+	Positive frequency out	0 to 10kHz
Freq-	Negative frequency out		
RS485 (MODBUS)	RS485A	Modbus terminal A	
	RS485B	Modbus terminal B	
Analog Loop 1	A1+	Positive analog out 1	4 to 20mA
	A1-	Negative analog out 1	
Analog Loop 2	A2+	Positive analog out 2	
	A2-	Negative analog out 2	

3.1.3 T1 version transmitter

3.1.3.1 The transmitter’s terminal layout is detailed in figure3-2, and the terminal functions are defined by figure 3-3. (Analog Loop 2 is not default option)

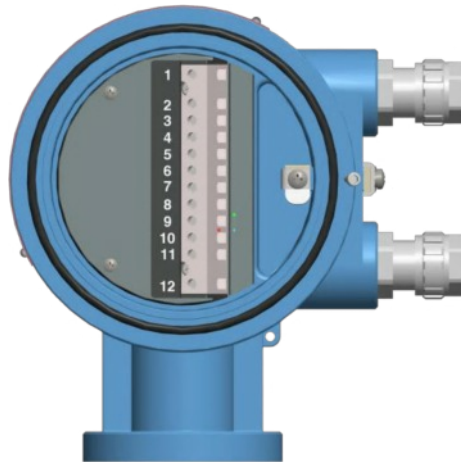

Figure 3-2 T1version transmitter terminal layout

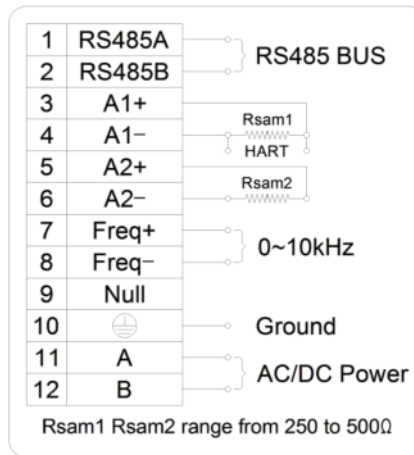

Figure 3-3 T1 version transmitter terminal description

3.2 Remote SCM Wiring

3.2.1 Transmitter Wiring

See section 3.1 for details.

3.2.2 Wiring between Sensor & Transmitter

Use only Walsn provided 9-wire cable (illustrated in figure 3-4) to connect the sensor to the transmitter.

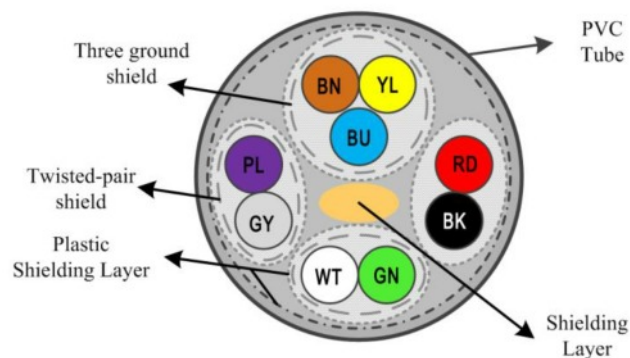

Figure 3-4 remote cable profile

3.2.3 Junction Box

3.2.3.1 T0 version transmitter

3.2.3.1.1 Junction box

The terminals inside the T0 transmitter junction box are arranged as illustrated in Figure 3-5 and the terminal functions are defined in Table 3-2.

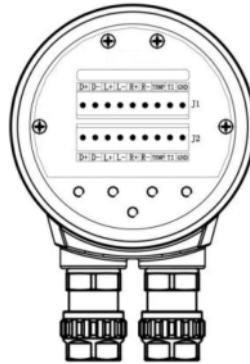



Figure 3-5 T0 transmitter junction box

Table 3-2 Terminal definition of T0 version transmitter conjunction box

Label	Description	Cable color
D+	Drive signal+	Red
D-	Drive signal-	Black
L+	Left pick up signal+	Purple
L-	Left pick up signal-	Grey
R+	Right pick up signal+	White
R-	Right pick up signal-	Green
TI	Temperature current	Brown
TEMP	Temperature pick up	Yellow
TGND	Temperature ground	Blue
	Shielding Ground	Non

3.2.3.2 T1, T2 and T3 version transmitters

3.2.3.2.1 Junction box

The terminals inside the T1, T2 & T3 transmitter junction box are illustrated in Figure 3-6, and the terminal functions are defined by Table 3-3

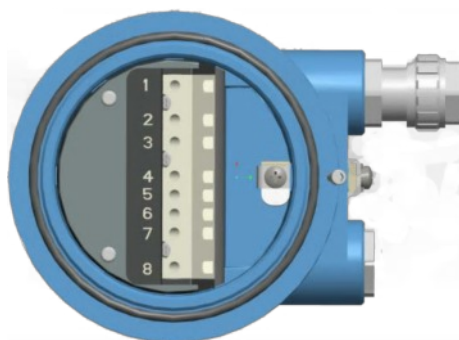



Figure 3-6 Remote conjunction box of T1, T2 and T3 version transmitter

Table 3-3 Remote terminal definition of T1/T2/T3 version transmitter

Label	Definition	Description	Cable Color
1	D+	Drive signal+	Red
2	D-	Drive signal-	Black
3	L+	Left pick up signal+	Purple
4	GND	Pick up signal ground	Grey+Green
5	R+	Right pick up signal+	White
6	TI	Temperature current	Brown
7	TEMP	Temperature pick up	Yellow
8	TGND	Temperature ground	Blue
Non		Shielding ground	Non

3.3 Grounding

3.3.1 Grounding through sensor terminal

If the process piping is grounded, the sensor can be grounded directly to the pipe system.

3.3.2 Grounding through transmitter terminal

If the pipeline is not conductive or otherwise ungrounded, the transmitter grounding terminal can be directly connected with the instrument protection grounding point.



3.4 Instructions and precautions

3.4.1 Wiring must be in accordance with the wiring diagram

The connecting line between transmitter connecting wire and sensor terminal box and transmitter junction box must be strictly in accordance with the wiring diagram, so as to make sure the connection is correct.

3.4.2 Cable arrangement

To avoid electromagnetic interference the cable connecting the sensor to the transmitter should be kept separate from all other wiring, and the transmitter's power supply and output cabling should not be near motors, other electrically noisy equipment, or their huge power supplies.

3.4.3 Using dedicate cable

The connection between the sensor and the transmitter must only be made using cabling provided by Walsn.

3.4.4 Grounding

3.4.4.1 Ensure that the inner and outer earth of the flow meter is in good condition.

3.4.4.2 Improper grounding may lead to the increase of measurement error.

3.4.5 Grounding wire resistance

The ground wire should be as short as possible, and the grounding resistance should be less than 4 Ω.

3.4.6 Draining point

All wiring should be set up draining point.

Chapter IV Initial start-up

4.1 Initial power up



Fully close and tighten all housing cover and cable wiring, improper sealing may lead to explosion risk in hazardous areas and/or damage to the meter due to moisture.

4.1.1 Power up

After the sensor and the transmitter are properly wired, the power supply can be switched on. In order to ensure accuracy the flow meter should be run for 15 minutes at least 50% full flow range. This allows the transmitter to achieve steady state operation and the flow tubes to reach the process temperature.

During the warm-up period, there will be a smaller range of volatility in display and output, this is a normal phenomenon.



4.2 Zero calibration

Different processes fluids, sensor orientations, and other such installation variables impact the response dynamics of the sensor. To account for these variations the transmitter must perform a zero calibration routine. This procedure must be performed with the sensor in its normal operating state, but with zero process flow. The procedure for zero calibration is outlined below:

4.2.1 Zero calibration condition

4.2.1.1 Powered up flow meter

4.2.1.2 The sensor tube remains full

4.2.1.3 No flow

4.2.2 Operation steps

4.2.2.1 Meet the zero calibration conditions.

4.2.2.2 Close the nearest shutoff valve in the downstream of the flow meter.

4.2.2.3 Close the nearest shutoff valve in the upstream of the flow meter.

4.2.2.4 Initiate the zero calibration using the transmitter's user interface (Figure 4-1)



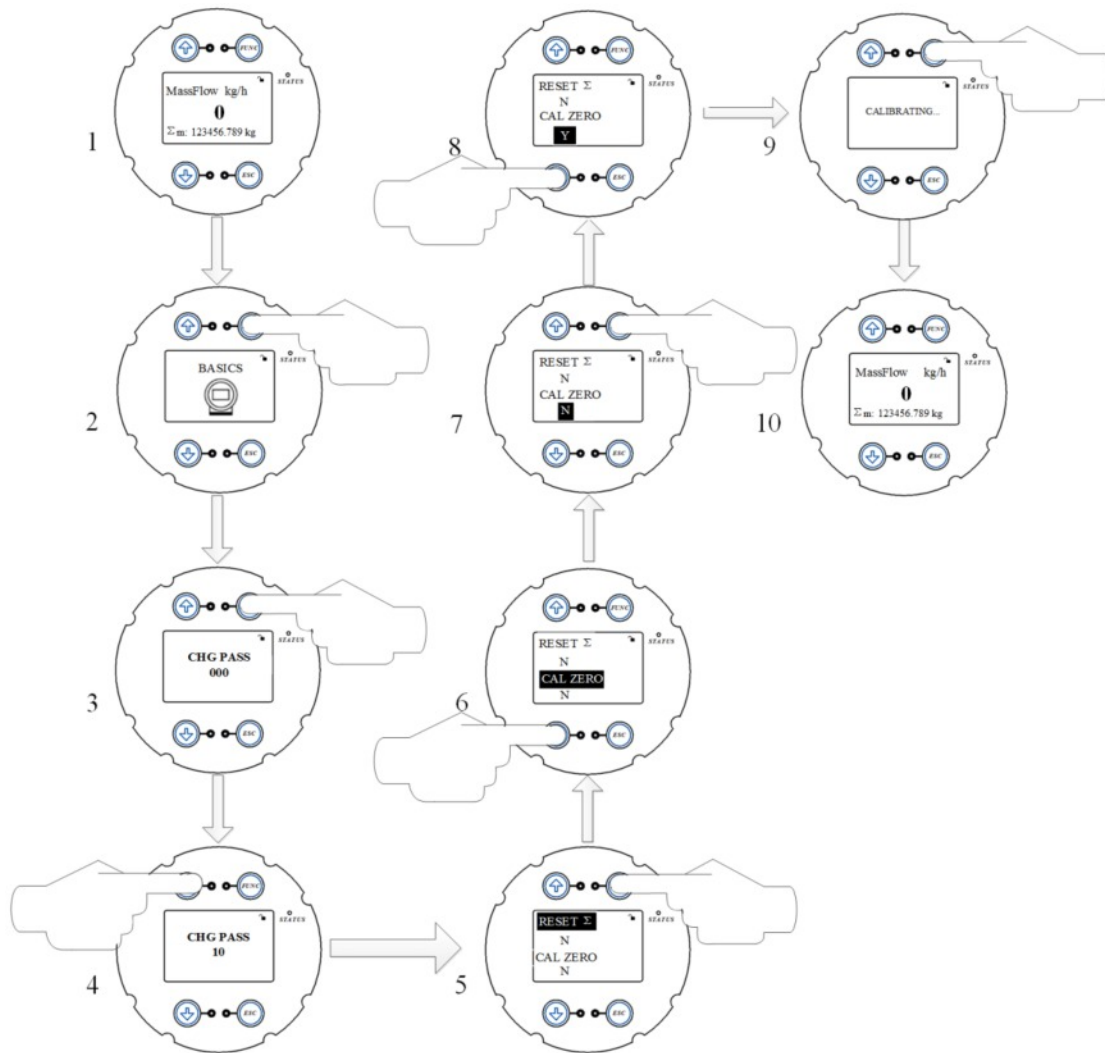

Figure 4-1 zero calibration with the user interface

4.2.3 Instructions and precautions



- 4.2.3.1 **Zero calibration must be performed after initial installation and after any installation configuration changes.**
- 4.2.3.2 **In the first month of use, it is good practice to check the Zero situation once a week and record the change. If the zero change is less than or equal to 5ns, the inspection cycle can be incrementally extended.**
- 4.2.3.3 **Zero point instability may indicate problems with the mechanical installation of the flowmeter (e.g. vibration interference)**

Chapter V Software operation guide of the transmitter

5.1 Operation panel

Operation panel of mass flow meter transmitter- See figure 5-1

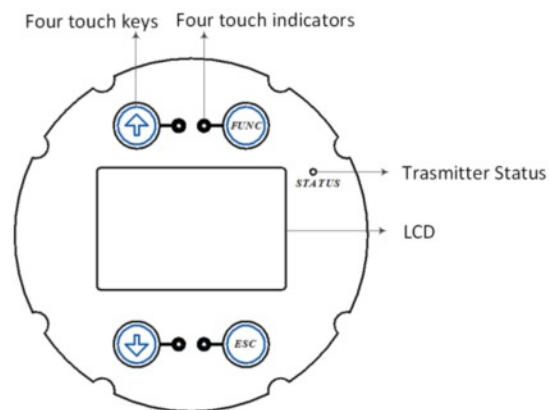







Figure 5-1 Operation panel of mass flowmeter transmitter

5.1.1 Touch keys

5.1.1.1 There are four touch keys on the Transmitter operation panel:

-  Up: Scroll up, or increment the selected value.
-  Down: Scroll down or reduce the selected value.
-  Function: Activate the selected function.
-  Cancel: Back out of the current selection or menu.

5.1.1.2 Symbol description of status indicator area

: Keys are locked.

: Keys are unlocked.

: The filtering coefficient is less than 0.21 and the absolute value of the phase difference is greater than 0.020us therefore zero calibration is necessary.

: The filtering coefficient is less than 0.21 and the absolute value of the phase difference is between 0.020us and 0.015us therefore zero calibration is recommended.

: A measured variable (either the primary or secondary display) is out of the range of the display. Adjust the display units.

5.1.1.3 Key operation

Touching the glass in front of key just like figure 5-2, the red indicator aside will light if operation is ok.

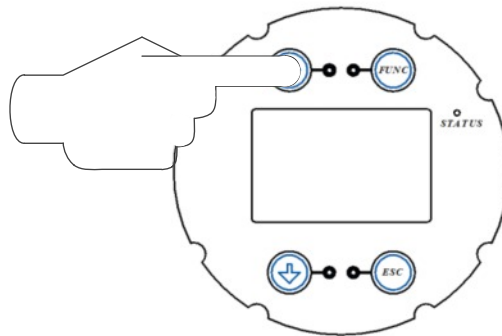

Figure 5-2 Touch key operation mode



5.1.1.4 Cautions

Do not rotate the front cover of the transmitter, or the transmitter key may not be able to respond. If done, reset the power.

5.1.2 Status indicator

A blinking green light indicates status means normal. The indicator will keep lighting or going out if there is anything faults.

5.1.3 LCD display screen

The transmitter operation panel is equipped with a LCD display with a resolution of 128 * 64, which is used to display the state parameters and configuration parameters.

5.2 Menu

5.2.1 Menu tree

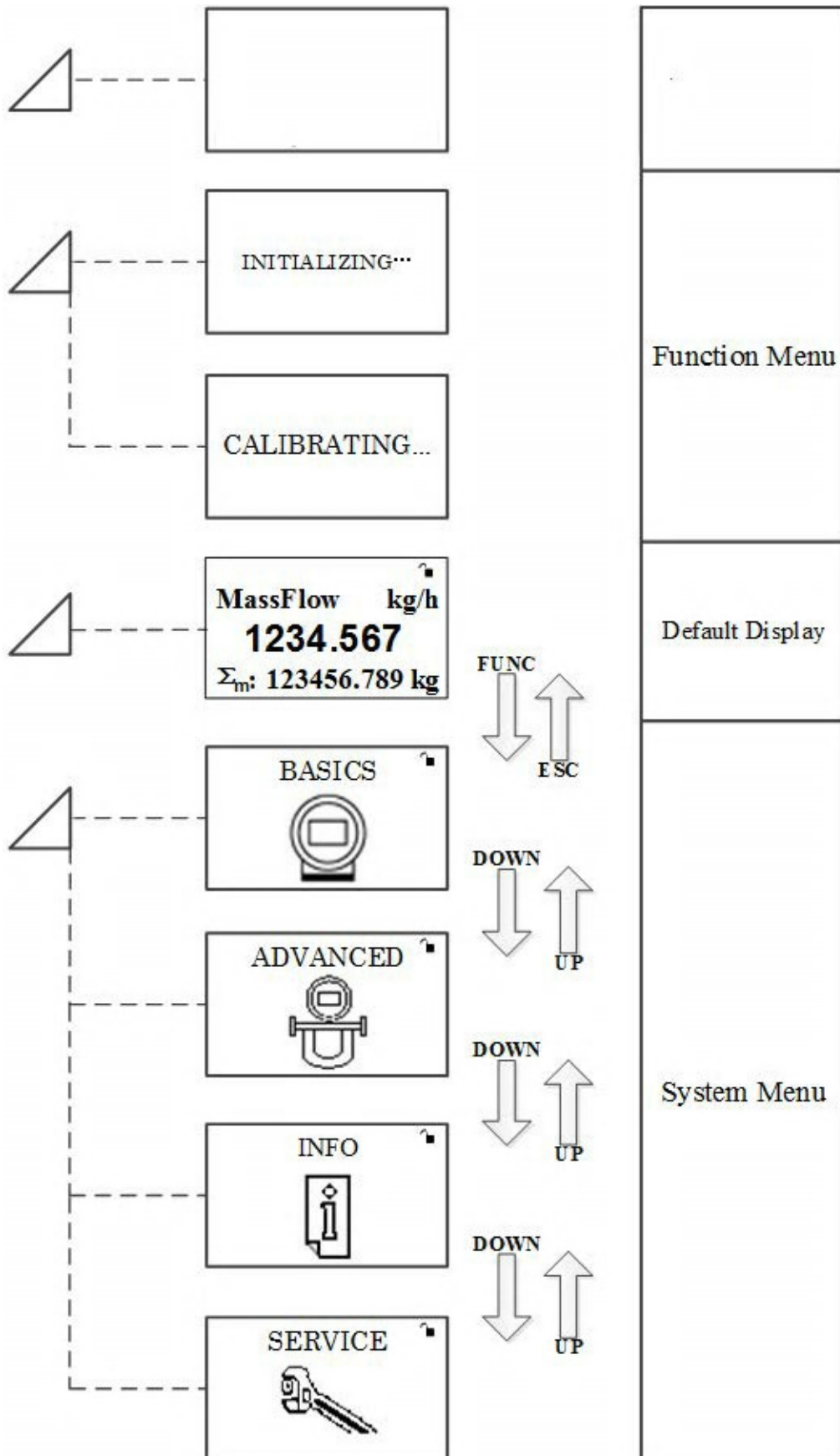

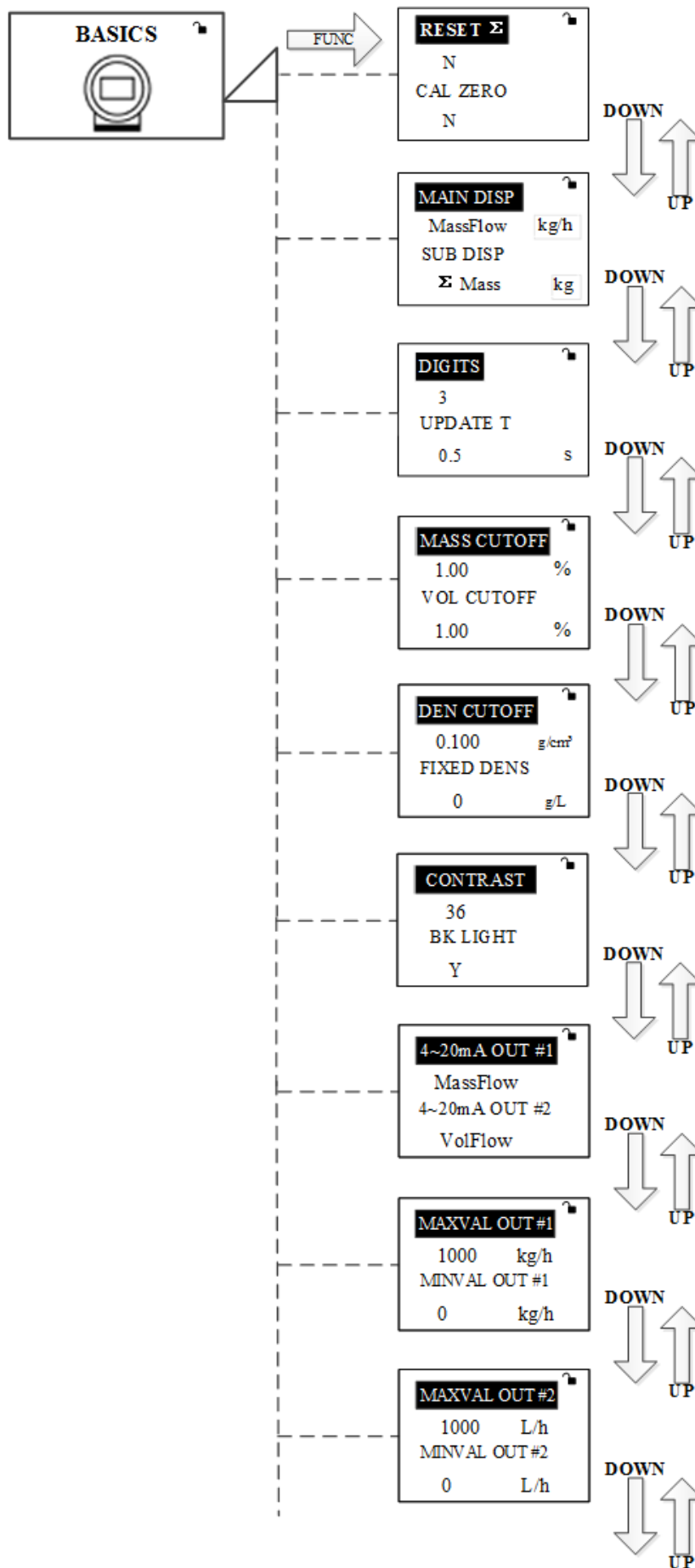

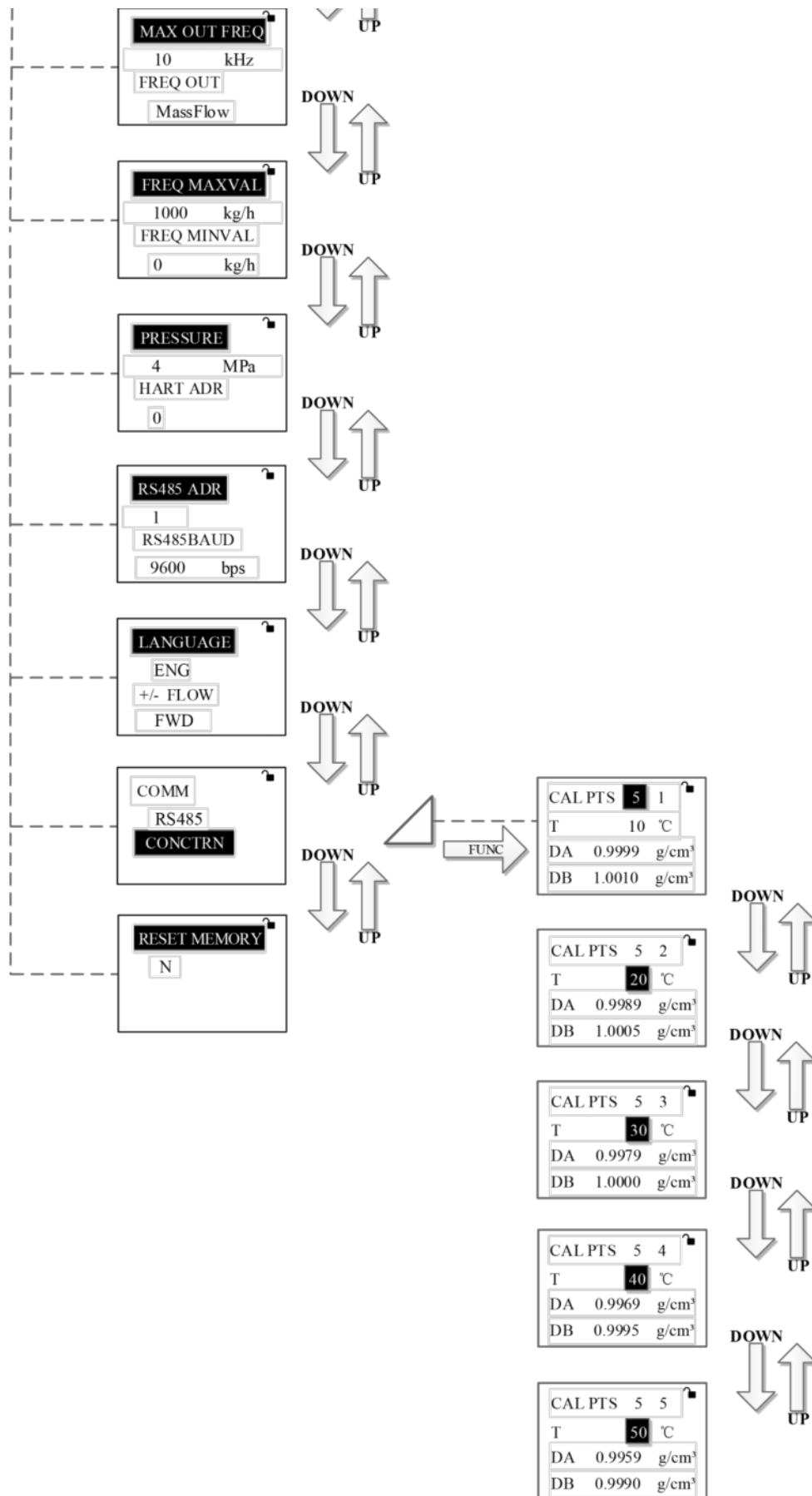

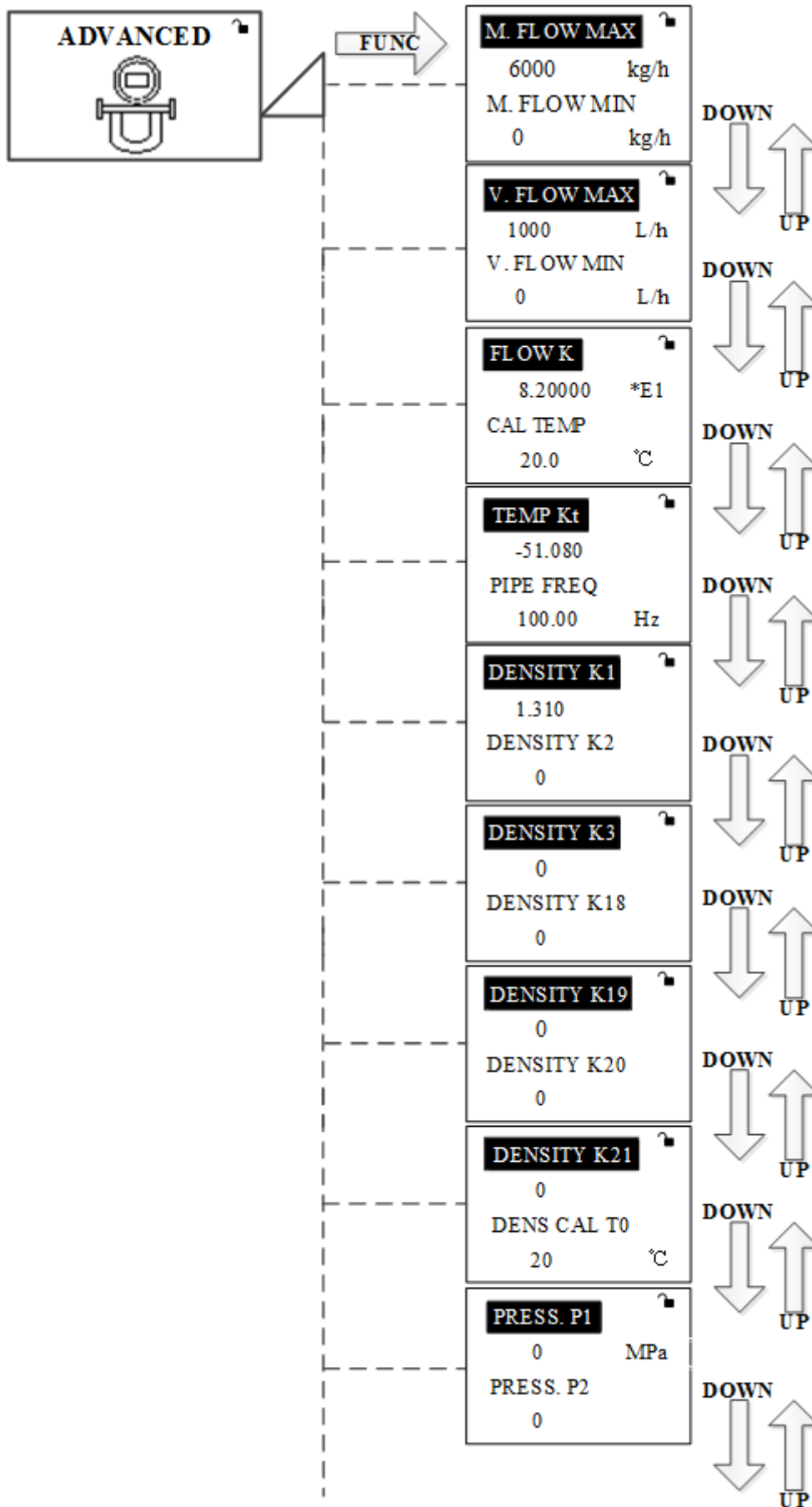

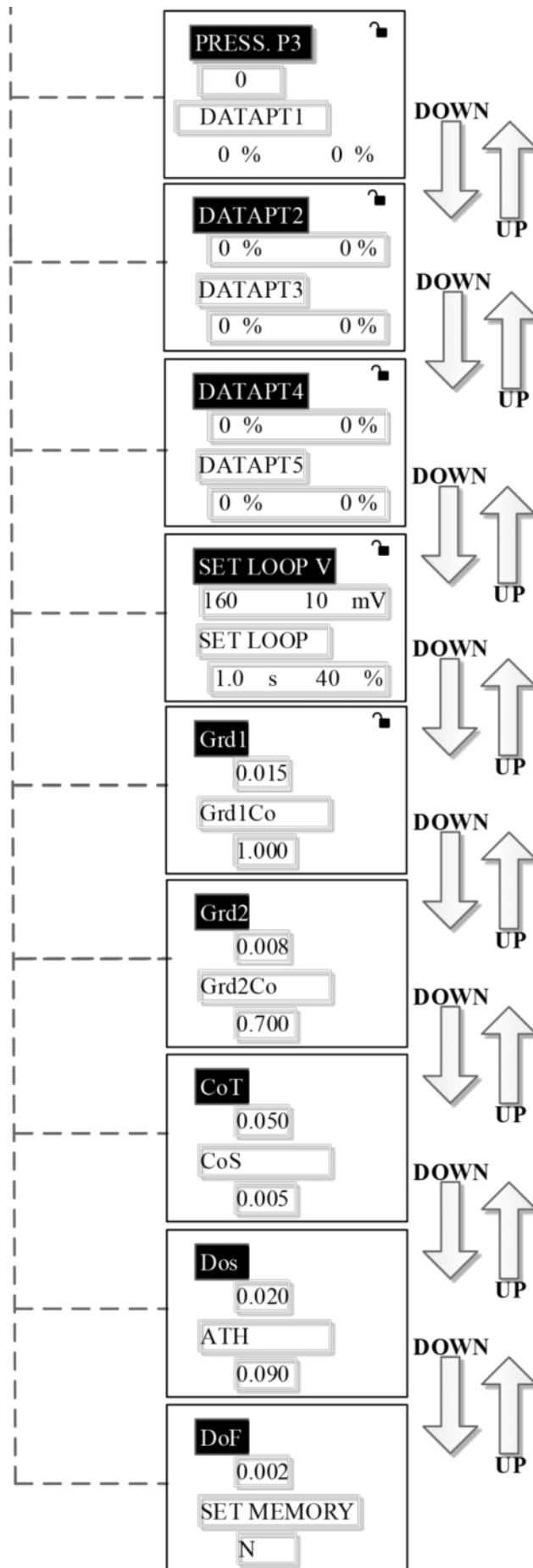

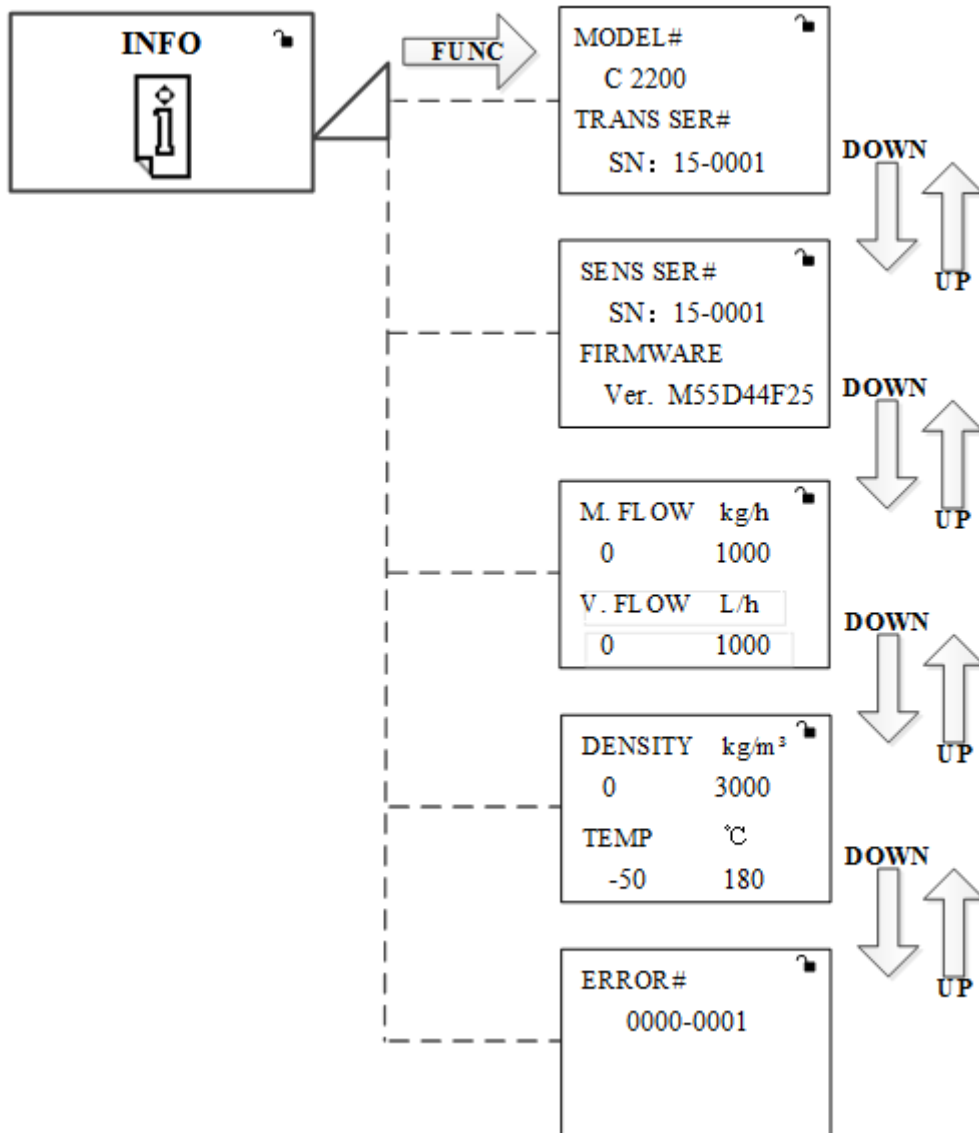

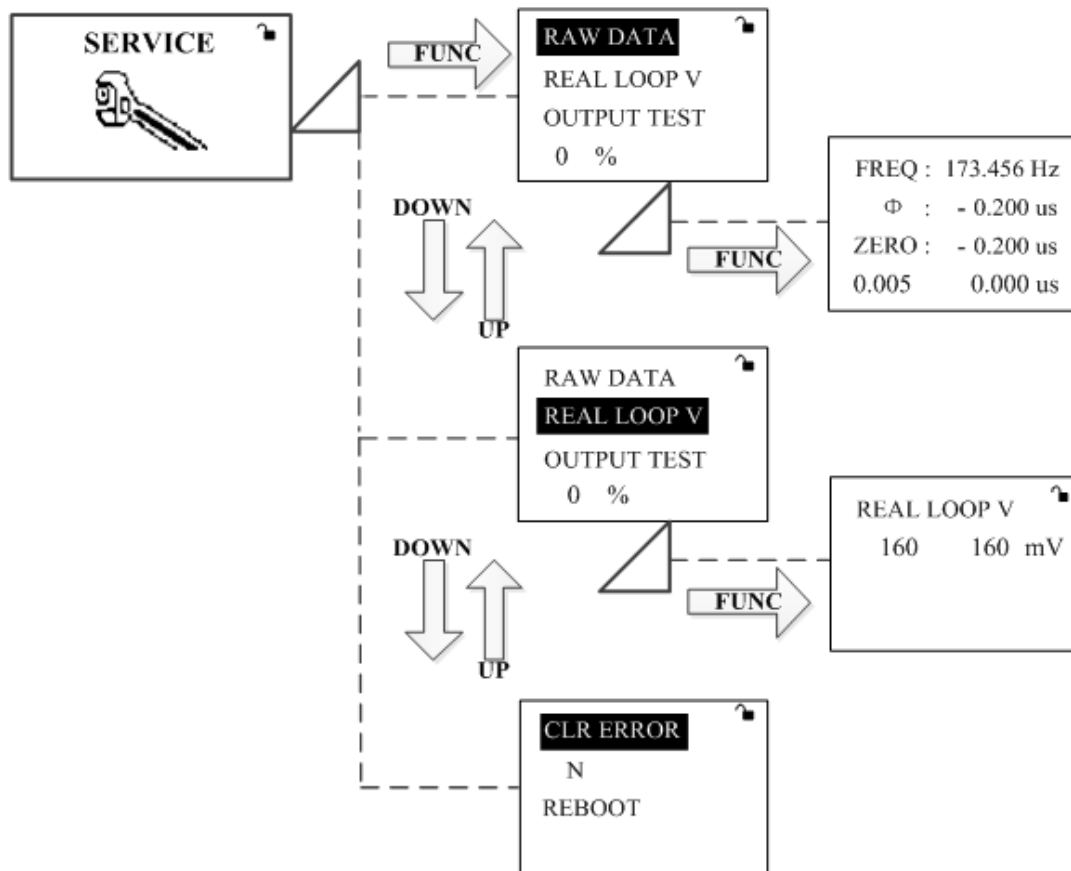

5.2.2 Boot

5.2.2.1 While powering on, the LCD will display the Walsn Logo and start to perform initialization operations and the status indicator light will flash. When booting and initialization is complete the main display screen will be displayed. This sequence is illustrated in Figure 5-4.

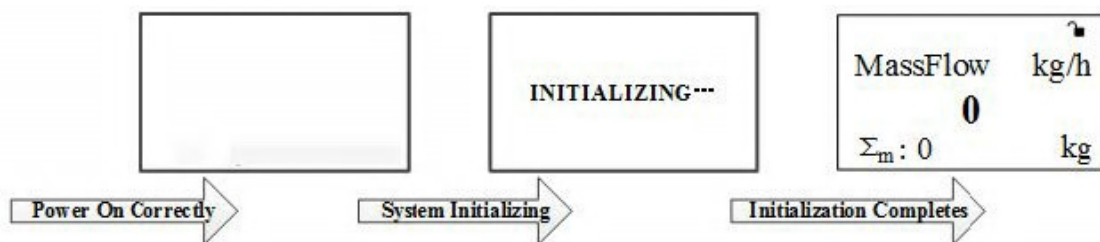

Figure 5-4 Boot display

5.2.2.2 If initialization fails: the progress bar will freeze, and the status indicator will assume a steady state (either on or off, but not blinking). Remove power & check the connection between the sensor and transmitter while failing.

5.2.2.3 The touch keys have self-locking function. When the flow meter enters the main screen after boot and initialization is complete, the keys will be in the default locked state. The will display in the top right corner of the LCD. To unlock: press "up" and "function" keys for 5 seconds, the symbol will be displayed to indicate the keys are unlocked. If 30 seconds elapse without detected key presses the keys will be relocked. The LCD will back the Main Screen automatically while all touch keys keep locking 5 minutes without any operation.

5.2.3 Main Screen

5.2.3.1 There are six measured variables which can be displayed on the main screen: Mass flow rate (Fm), totalized mass flow (Σm), volumetric flow rate (Fv), totalized volumetric flow (Σv), temperature (T), or density (D).

5.2.3.2 There are two displays on the main screen: primary display and the secondary display. The primary display can be any one of the 6 measured variables and the remaining 5 variables shown individually on the secondary display which can be cycled through as shown in figure 5-5.

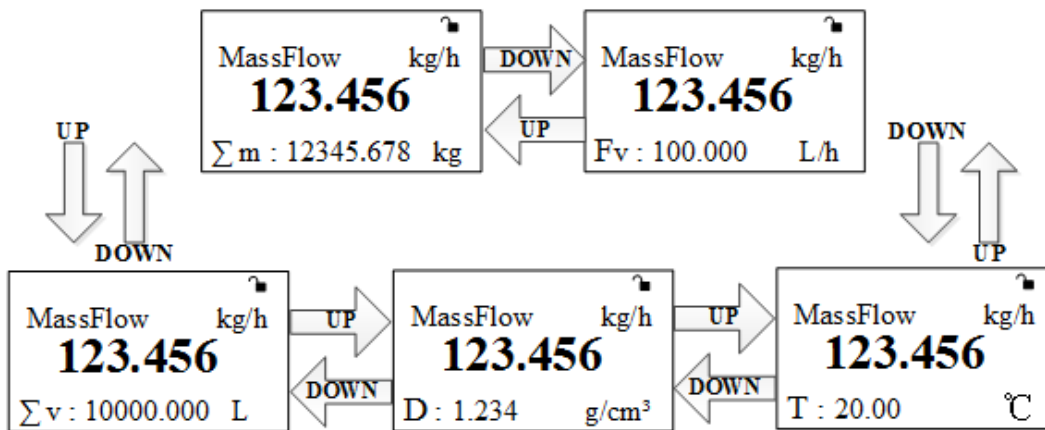

Figure 5-5 main screen of transmitter

5.2.3.3 The upper part of the LCD display is the status indicator, as shown in the dotted line in Figure 5-6.

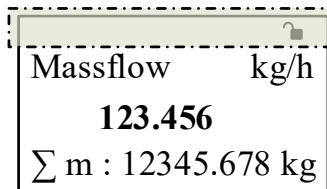

Figure 5-6 status indicator

5.2.3.4 Symbol description of status indicator area

- 🔒: Touch key has been locked.
- 🔓: Touch key has been unlocked.
- ↔: Filtering coefficient is less than 0.21 (meet the zero condition), and the absolute value of the phase difference is greater than 0.020us. It means “zero calibration” is necessary.
- 💧: Filtering coefficient is less than 0.21 (meet the zero condition), and the absolute value of the phase difference is between 0.020us and 0.015us. It means “zero calibration” is recommended.
- ⊖⊖: The primary and secondary display overflow. Please change the display variable unit.
- : Tube process frequency is far from empty pipe frequency over 40%.

5.2.4 Secondary Screen

5.2.4.1 The transmitter contains four sub-menus, which are: BASICS, ADVANCED, INFO, and SERVICE. To enter the menu system from the main display use the “FUNC” key as illustrated in figure 5-7.

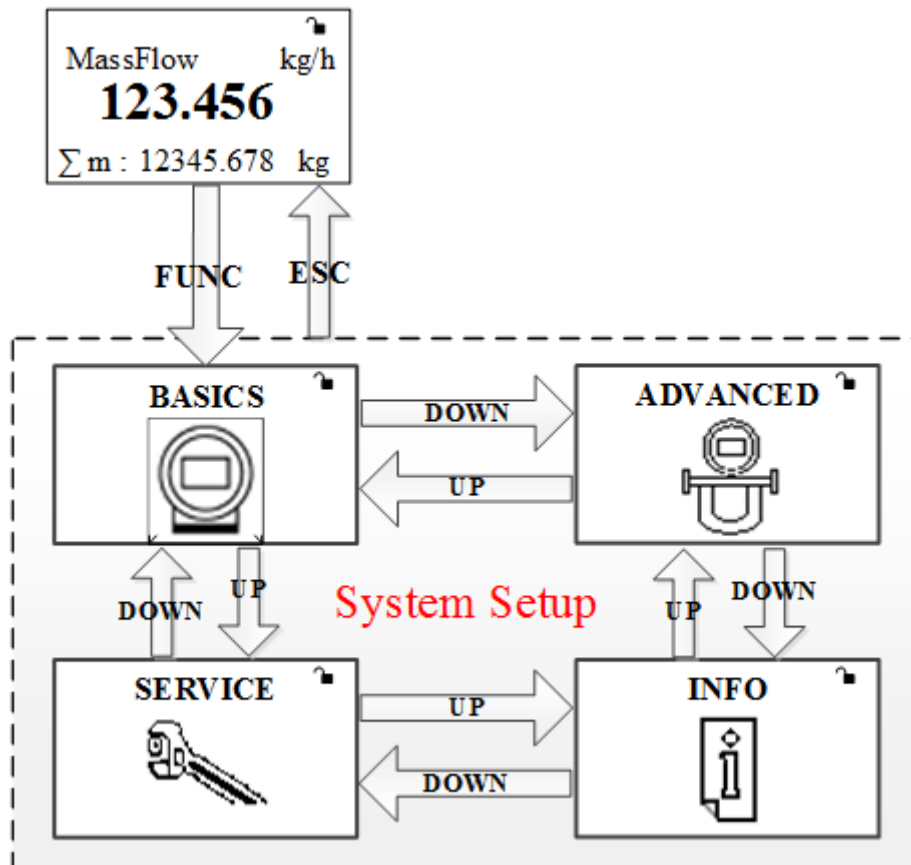

Figure 5-7 secondary interface

5.2.4.2 In the main interface, press the “FUNC” key to enter the secondary interface. In the secondary interface, Press "UP" or "DOWN", the four secondary interfaces can be scrolled, Press "ESC" to return to the main interface.

5.2.5 BASICS

5.2.5.1 To enter the “BASICS” menu: scroll through the menu to find “BASICS”, press “FUNC”, and enter the password “10”.

5.2.5.2 After entering the menu, use “UP” or “DOWN” to select specific parameters, “FUNC” to enter select a parameter to modify and, “UP” or “DOWN” to modify the selected parameter. Press “FUNC” to confirm the change and “ESC” to exit out of the menu.

5.2.5.3 The third Screen of BASICS

5.2.5.3.1 RESET Σ

Reset the flow totalizers.

5.2.5.3.2 CAL ZERO

Perform the zero calibration procedure (See section 4.1.2)

5.2.5.3.3 MAIN DISP

Configure the measured variable & unit (see table 5-1) displayed in primary display.

5.2.5.3.4 SUB DISP

Configure the measured variable & unit (see table 5-1) displayed in secondary display .

Table 5-1 Display variable and corresponding unit

Display variable	Optional unit					Default unit
Mass flow (Fm)	g/s	g/min	g/h	kg/s	kg/min	kg/h
	kg/h	kg/day	t/s	t/min	t/h	
	t/day	lb/s	lb/min	lb/h	lb/day	
Volume flow (Fv)	mL/s	mL/min	mL/h	L/s	L/min	L/h
	L/h	L/day	m ³ /s	m ³ /min	m ³ /h	
	m ³ /day	USGPS	USGPM	USGPH	USGPD	
Total mass (Σm)	g	kg	t	lb		kg
Total volume (Σv)	mL	L	m ³	USGAL		L
Density (D)	g/cm ³	g/L	kg/L	kg/m ³	t/m ³	g/cm ³
	lb/gal					
Temperature (T)	°C	°F				°C

5.2.5.3.5 DIGITS

Set the number of decimals to display on the primary and secondary display, the range: 0-3.

5.2.5.3.6 UPDATE T

Set the damping time. The output is the average value measured across the interval.

5.2.5.3.6.1 Refresh damping setting range: 0s-20s.

5.2.5.3.6.2 If the filter coefficient is less than ATH, the flow is stable, and at this time, the average output of the refresh time is adopted.

5.2.5.3.6.3 If the filter coefficient is greater than ATH, that the flow in the dynamic process and at this time the refresh time is invalid, the output value is the direct measurement value.

5.2.5.3.6.4 If the site noise is high & the filter coefficient is keeping higher than ATH, that means refresh time keeping invalid. Following the ATH can be set higher, allowing the damping output Under the condition of a higher filter coefficient.

5.2.5.3.7 MASS CUTOFF

5.2.5.3.7.1 Set the mass low flow cutoff ratio. Setting range 0%~50% ("M.FLOW" in "INFO").

5.2.5.3.7.2 The default value is 1%

5.2.5.3.7.3 When "mass flow" < ("MASS CUTOFF" x "M.FLOW"), the output mass flow is driven to "zero".

5.2.5.3.8 VOL CUTOFF

5.2.5.3.8.1 Set the volumetric low flow cutoff ratio. Setting range 0%-50% ("V.FLOW" in "INFO").

5.2.5.3.8.2 The default value is 1%.

5.2.5.3.8.3 When "volume flow" < ("VOL CUTOFF" x "V.FLOW"), the output volume flow is driven to "zero".

5.2.5.3.9 DEN CUTOFF

Set the low density cutoff value (0g/cm³ to 3g/cm³). The output is driven to "0" while the measured densities below the value.

5.2.5.3.10 FIXED DENS

5.2.5.3.10.1 When the input value is "0", the displayed density is the measured value, "volume

flow" = "mass flow"/"measured density".

5.2.5.3.10.2 When the input value is not zero, the displayed density is the measured value,
"volume flow" = "mass flow"/"input density".

5.2.5.3.10.3 Input Range: 0g/cm³ to 3g/cm³

5.2.5.3.11 CONTRAST

5.2.5.3.11.1 Set the contrast ratio of LCD display screen, if the LCD display is fuzzy, you can adjust this to show clear.

5.2.5.3.11.2 Setting range: 25-50.

5.2.5.3.11.3 Default: 36.

5.2.5.3.12 BK LIGHT

Turn on or off the LCD display backlight.

5.2.5.3.13 4~20mA OUT #1

Configure which measured variable is output on Analog current loop #1 (4-20mA).
Available measured variables: mass flow, temperature, density & volume flow.

5.2.5.3.14 4~20mA OUT #2

Configure which measured variable is output on Analog current loop #2 (4-20mA).

5.2.5.3.14.1 Only double current loop products available.

5.2.5.3.14.2 Available measured information: mass flow, volume flow, density, temperature.

5.2.5.3.14.3 M1/M(Mass Ratio)/V1/V(Volume Ratio) could be configured while "COMM" is "RS485"

5.2.5.3.15 MAXVAL OUT #1

Set the upper range value of 20mA for "4~20mA OUT #1". The output value will continue indicated the variable within 20.5mA.

5.2.5.3.16 MINVAL OUT #1

5.2.5.3.16.1 Set the lower range value of 4mA for "4~20mA OUT #1". The output value will continue indicated the variable no less than 3.8mA.

5.2.5.3.16.2 When output variable is density, if the measured density is below the set value of "MINVAL OUT #1", output current value is driven to 2mA.

5.2.5.3.17 MAXVAL OUT #2

5.2.5.3.17.1 Only double current loop products available.

5.2.5.3.17.2 Set the upper range value of 20mA for "4~20mA OUT #2".

5.2.5.3.17.3 The output value will continue indicated the variable within 20.5mA.

5.2.5.3.17.4 While "4~20mA #2" is configured "M1/M" or "V1/V", "MAXVAL OUT2#" should be 100% and the value & unit will be no avail.

5.2.5.3.18 MINVAL OUT #2

5.2.5.3.18.1 Only double current loop products available.

5.2.5.3.18.2 Set the lower range value of 4mA for "4~20mA OUT #2".

5.2.5.3.18.3 The output value will continue indicated the variable no less than 3.8mA.

5.2.5.3.18.4 When output variable is density, if the measured density is below the set value of "MINVAL OUT #2", output current value is driven to 2mA.

5.2.5.3.18.5 While "4~20mA #2" is configured "M1/M" or "V1/V", "MINVAL OUT2#" should be 0% and the value & unit will be no avail.

5.2.5.3.19 MAX OUT FREQ

- 5.2.5.3.19.1 Set the upper limit of the frequency / pulse output, the setting range is 1KHz-10KHz.
- 5.2.5.3.19.2 The physical limit of the frequency output is 12.5KHz.
- 5.2.5.3.20 **FREQ OUT**
 - 5.2.5.3.20.1 Configure which measured variable is output on the frequency/pulse output channel.
 - 5.2.5.3.20.2 Options are: mass flow, volume flow.
- 5.2.5.3.21 **FREQ MAXVAL**
 - Set the upper range value of flow.
- 5.2.5.3.22 **FREQ MINVAL**
 - Set the lower range value of flow.
- 5.2.5.3.23 **PRESSURE**
 - 5.2.5.3.23.1 Set the value of process pressure. This value is used to compensate the deviation cause by process pressure.
 - 5.2.5.3.23.2 When the process pressure is higher than 5MPa, the PRESSURE is necessary.
 - 5.2.5.3.23.3 Setting range: 0MPa-50MPa.
- 5.2.5.3.24 **HART ADR**
 - 5.2.5.3.24.1 HART communication address.
 - 5.2.5.3.24.2 Setting range: 0-63.
 - 5.2.5.3.24.3 Default: 0.
- 5.2.5.3.25 **RS485 ADR**
 - 5.2.5.3.25.1 RS485 (MODBUS) communication address.
 - 5.2.5.3.25.2 Setting range: 0-63.
 - 5.2.5.3.25.3 Default: 1.
- 5.2.5.3.26 **RS485 BAUD**
 - 5.2.5.3.26.1 Baud rate for RS485 communication.
 - 5.2.5.3.26.2 Option: 1200, 2400, 4800 & 9600.
 - 5.2.5.3.26.3 Default: 9600.
- 5.2.5.3.27 **LANGUAGE**
 - 5.2.5.3.27.1 Set the menu language.
 - 5.2.5.3.27.2 Setting range: English.
- 5.2.5.3.28 **+/- FLOW**
 - 5.2.5.3.28.1 Choose flow directions.
 - 5.2.5.3.28.2 Options: FWD (flow arrow direction), ABS, 2 WAY & REV
 - 5.2.5.3.28.2.1 FWD: If the detected flow value is less than zero (i.e. backwards relative to the default flow direction), it shows that the output flow rate is zero. Totalizers indicate total forward flow. See table 5-2.
 - 5.2.5.3.28.2.2 ABS: The instrument shows absolute value of flow. Totalizers indicate absolute amount of flow. See table 5-2.
 - 5.2.5.3.28.2.3 2 WAY: The instrument shows both positive and negative values, corresponding to the actual direction of flow. Totalizers indicate net flow
 - 5.2.5.3.28.2.4 REV: Identical to "forward" but positive flow is defined as opposite the default flow direction. See table 5-2.
 - 5.2.5.3.28.3 Recommended settings

5.2.5.3.28.3.1 When the fluid direction is set to the FWD, reverse or absolute value, Qmax and Qmin should be ≥ 0 , and $Q_{max} > Q_{min}$.

5.2.5.3.28.3.2 When the fluid direction is set "2 WAY", $Q_{max} > 0$, $Q_{min} < 0$, See table 5-2.

Table 5-2 Mass flowmeter flow direction

Mass flowmeter flow direction						
Flow direction setting	condition	display	Qmax	Qmin	Output (mA)	Cumulative flow
FWD	Flow matches direction of forward flow indicator	Flow	0~99999	0	4 to 20	Totalizer increased
	Flow opposite forward flow indicator	0			4	No change
REV	Flow matches direction of forward flow indicator	0	0~99999	0	4	No change
	Flow opposite forward flow indicator	Flow			4~20	Totalizer increased
ABS	Flow matches direction of forward flow indicator	Flow	0~99999	0	4~20	Totalizer increased
	Flow opposite forward flow indicator	Flow			4~20	Totalizer increased
2 WAY	Flow matches direction of forward flow indicator	+ Flow	0~99999	-99999~0	4~20	Totalizer increased
	Flow opposite forward flow indicator	- Flow				Totalizer decreased

Note: 1: $Q_{max} - Q_{min} \geq 20\%$ flow range (see PDS) ; 2: $Q_{min} = 0 \sim Q_{max}$ (non bi-directional flow setting)

5.2.5.3.29 COMM

5.2.5.3.29.1 Set flow meter communication mode.

5.2.5.3.29.2 Option: RS485 (Modbus RTU), HART.

5.2.5.3.30 CONCTRN

5.2.5.3.30.1 Input raw data for calculating the concentration.

5.2.5.3.30.2 CAL PTS: input points, 0~5

5.2.5.3.30.3 T/DA/DB: input Temperature, Density(A) & Density(B) for each point.

5.2.5.3.30.4 Temperature input range: -50°C~300°C

5.2.5.3.30.5 Density input range: 0g/cm³~3 g/cm³

5.2.5.3.31 RESET MEMORY

Restore the configuration to the factory default.

5.2.6 ADVANCED

5.2.6.1 In the “ADVANCED” of the secondary interface, press “FUNC” to enter the third level interface. Set password: 995.

5.2.6.2 After entering third level interface, press “UP” or “DOWN” to select specific setting items, and press “FUNC” to enter setting information, press “UP” or “DOWN” to change parameters, press “FUNC” to confirm, and press “ESC” to exit.

5.2.6.3 Third level interface of ADVANCED

5.2.6.3.1 M.FLOW MAX

5.2.6.3.1.1 Set the flow meter's mass flow range upper limit value.

5.2.6.3.1.2 When this value is less than 100Kg/h, the K coefficient is magnified 100 times.

5.2.6.3.1.3 This value is the point of nonlinear correction 100% point.

5.2.6.3.2 M.FLOW MIN

Set the flow meter's mass flow range lower limit value.

5.2.6.3.3 V.FLOW MAX

Set the flow meter's volume flow range upper limit value.

5.2.6.3.4 V.FLOW MIN

Set the flow meter's volume flow range lower limit value.

5.2.6.3.5 FLOW K

Definition: the corresponding mass flow of Unit phase difference.

5.2.6.3.5.1 Set flow coefficient of flow meter

5.2.6.3.5.2 This parameter contains two parts: Coefficient part and index part. Flow coefficient = coefficient x 10^{index}.

5.2.6.3.5.2.1 Coefficient section setting range: 0.00000-9.99999.

5.2.6.3.5.2.2 Index part setting range: 0-4.

5.2.6.3.5.3 **Matters needing attention**

Flow coefficient has been set by the factory, non annual inspection or professional personnel do not operate.

5.2.6.3.6 CAL TEMP

5.2.6.3.6.1 Process temperature of flow meter calibration.

5.2.6.3.6.2 **Matters needing attention**

CAL TEMP has been set by the factory, non annual inspection or professional personnel do not operate.

5.2.6.3.7 TEMP K_t

5.2.6.3.7.1 Temperature compensation coefficient of flow meter.

5.2.6.3.7.2 **Matters needing attention**

The temperature coefficient K_t has been set by the factory before the, non annual inspection or professional personnel do not operate.

5.2.6.3.7.3 Flow temperature correction

Formula: $Q_T = Q \times (k_t \times (t - t_0) \times 10^{-5} + 1)$

Definition: Q_T: Flow after Compensation

Q: Flow before Compensation

K_t: Temperature correction coefficient

T: Process temperature

t₀: Calibration temperature



5.2.6.3.8 PIPE FREQ

5.2.6.3.8.1 Record the vibration frequency of empty flow tube.

5.2.6.3.8.2 Matters needing attention

PIPE FREQ has been set by the factory, non annual inspection or professional personnel do not operate.



5.2.6.3.9 DENSITY K_1

5.2.6.3.9.1 Set the density coefficient of flow meter: K_1 .

5.2.6.3.9.2 Matters needing attention

The density coefficient K_1 has been set by the factory, non annual inspection or professional personnel do not operate.



5.2.6.3.10 DENSITY K_2

5.2.6.3.10.1 Set the density coefficient of flow meter: K_2 .

5.2.6.3.10.2 Matters needing attention

The density coefficient K_2 has been set by the factory, non annual inspection or professional personnel do not operate.



5.2.6.3.11 DENSITY K_3

5.2.6.3.11.1 Set the density coefficient of flow meter: K_3 .

5.2.6.3.11.2 Matters needing attention

The density coefficient K_3 has been set by the factory, non annual inspection or professional personnel do not operate.



5.2.6.3.12 DENSITY K_{18}

5.2.6.3.12.1 Set the density coefficient of flow meter: K_{18} .

5.2.6.3.12.2 Matters needing attention

The density coefficient K_{18} has been set by the factory, non annual inspection or professional personnel do not operate.



5.2.6.3.13 DENSITY K_{19}

5.2.6.3.13.1 Set the density coefficient of flow meter: K_{19} .

5.2.6.3.13.2 Matters needing attention

The density coefficient K_{19} has been set by the factory, non annual inspection or professional personnel do not operate.



5.2.6.3.14 DENSITY K_{20}

5.2.6.3.14.1 Set the density coefficient of flow meter: K_{20} .

5.2.6.3.14.2 Matters needing attention

The density coefficient K_{20} has been set by the factory, non annual inspection or professional personnel do not operate.



5.2.6.3.15 DENSITY K_{21}

5.2.6.3.15.1 Set the density coefficient of flow meter: K_{21} .

5.2.6.3.15.2 Matters needing attention

The density coefficient K_{21} has been set by the factory, non annual inspection or professional personnel do not operate.



5.2.6.3.16 DENS CAL T0

5.2.6.3.16.1 Record the temperature while density calibration, which is used for compensating density measurement deviation caused by process temperature changing.

5.2.6.3.16.2 Matters needing attention



DENS CAL T0 has been set by the factory, non annual inspection or professional personnel do not operate.

5.2.6.3.16.3 Temperature correction of density

Using the traditional method to calculate the density of the medium (The density coefficient $K_2 = K_3 = 0$).

$$\rho = K_1 \times \left(\frac{1 - 0.000475 \times (t - t_0) \times f_E^2}{f_W^2} - 1 \right)$$

Definition: ρ : Density of the media

K_1 : DENSITY K_1

t : Process temperature

t_0 : DENS CAL T0

f_E : PIPE REEQ

f_W : Process Tube Frequency

5.2.6.3.17 PRESS. P1

5.2.6.3.17.1 Set flow pressure coefficient P1.

5.2.6.3.17.2 Matters needing attention

Pressure coefficient P1 has been set by the factory, non annual inspection or professional personnel do not operate.



5.2.6.3.18 PRESS. P2

5.2.6.3.18.1 Set flow pressure coefficient P2.

5.2.6.3.18.2 Matters needing attention

Pressure coefficient P2 has been set by the factory, non annual inspection or professional personnel do not operate.



5.2.6.3.19 PRESS. P3

5.2.6.3.19.1 Set flow pressure coefficient P3.

5.2.6.3.19.2 Matters needing attention

Pressure coefficient P3 has been set by the factory, non annual inspection or professional personnel do not operate.



5.2.6.3.20 DATAPT1

5.2.6.3.20.1 Setting sensor nonlinear correction point 1.

5.2.6.3.20.2 This point can only be 100%.

5.2.6.3.21 DATAPT2

Set sensor nonlinear correction point 2.

5.2.6.3.22 DATAPT 3

Set sensor nonlinear correction point 3.

5.2.6.3.23 DATAPT 4

Set sensor nonlinear correction point 4.

5.2.6.3.24 DATAPT 5

Set sensor nonlinear correction point 5.

5.2.6.3.25 SET LOOP V

5.2.6.3.25.1 Setting the voltage amplitude of the sensor pick up coil & low alarm level.



5.2.6.3.25.2 Matters needing attention

SET LOOP V has been set by the factory, non annual inspection or professional personnel do not operate.

5.2.6.3.26 SET LOOP

5.2.6.3.26.1 Setting the Delay time and the Percentage that process frequency compare with empty pipe. Once process frequency comes over the percentage, the output will keep the last values (Mass Flow/Volume Flow/Density). If the process frequency comes over the percentage & keeps over the delay time, the outputs drive to "0".

5.2.6.3.26.2 Default: 1.0 s & 40%

5.2.6.3.27 Grd1

5.2.6.3.27.1 The threshold value 1 of flow changing slope.

5.2.6.3.27.2 Default: 0.015.



5.2.6.3.27.3 Matters needing attention

The Grd1 has been set by the factory, non annual inspection or professional personnel do not operate.

5.2.6.3.28 Grd1Co

5.2.6.3.28.1 The adopted filter coefficient when flow change slope > Grd1 or frequency variation > DoF.

5.2.6.3.28.2 Default: 1.000.



5.2.6.3.28.3 Matters needing attention

The Grd1C has been set by the factory, non annual inspection or professional personnel do not operate.

5.2.6.3.29 Grd2

5.2.6.3.29.1 The threshold value 2 of flow change slope.

5.2.6.3.29.2 Default: 0.008.



5.2.6.3.29.3 Matters needing attention

The Grd2 has been set by the factory, non annual inspection or professional personnel do not operate.

5.2.6.3.30 Grd2Co

5.2.6.3.30.1 The adopted filter coefficient when Grd1 > flow change slope > Grd2.

5.2.6.3.30.2 Default: 0.700.



5.2.6.3.30.3 Matters needing attention

The Grd2C has been set by the factory, non annual inspection or professional personnel do not operate.

5.2.6.3.31 CoT

5.2.6.3.31.1 The adopted filter coefficient when flow change slope < Grd2, and phase difference > DoS.

5.2.6.3.31.2 Default: 0.050.



5.2.6.3.31.3 Matters needing attention

The CoT has been set by the factory, non annual inspection or professional personnel do not operate.

5.2.6.3.32 CoS

5.2.6.3.32.1 The adopted filter coefficient when flow change slope < Grd2, and phase difference < DoS.



5.2.6.3.32.2 Default: 0.005.

5.2.6.3.32.3 Matters needing attention

The CoS has been set by the factory, non annual inspection or professional personnel do not operate.

5.2.6.3.33 DoS

5.2.6.3.33.1 The threshold value of phase difference when flow change slope < Grd2.

5.2.6.3.33.2 Default: 0.020.



5.2.6.3.33.3 Matters needing attention

The DoS has been set by the factory, non annual inspection or professional personnel do not operate.

5.2.6.3.34 ATH

5.2.6.3.34.1 Refresh damping to judge threshold value, when filter coefficient > ATH, the displayed output is direct measured data.

5.2.6.3.34.2 Default: 0.090.



5.2.6.3.34.3 Matters needing attention

The ATH has been set by the factory, non annual inspection or professional personnel do not operate.

5.2.6.3.35 DoF

5.2.6.3.35.1 The threshold value of tube vibration frequency.

5.2.6.3.35.2 Default: 0.002.



5.2.6.3.35.3 Matters needing attention

The DoF has been set by the factory, non annual inspection or professional personnel do not operate.

5.2.6.3.36 SET MEMORY

5.2.6.3.36.1 Store the current manufacturer setting parameters as factory settings, if the implementing this setting, it will cover the original factory settings.



5.2.6.3.36.2 Matters needing attention

Non annual inspection or professional personnel do not operate.

5.2.7 INFO

5.2.7.1 Under the "INFO" of secondary interface, press "FUNC" to enter the third level interface.

5.2.7.2 After entering the third level interface, press "UP" or "DOWN" for scrolling, and press "ESC" to exit.



5.2.7.3 All items within this menu are read only.

5.2.7.4 INFO third level interface

5.2.7.4.1 MODEL #

Displaying the model of transmitter used.

5.2.7.4.2 TRANS SER #

Displaying the serial number of transmitter used.

5.2.7.4.3 SENS SER #

Displaying the serial number of sensor used.

5.2.7.4.4 FIRMWARE

Displaying the version of software used.

5.2.7.4.5 M. FLOW kg/h

Display the lower and upper mass range value.

5.2.7.4.6 V. FLOW L/h

Display the lower and upper volume range value.

5.2.7.4.7 DENSITY kg/m³

Display the lower and upper density range value.

5.2.7.4.8 TEMP °C

Display the lower and upper temperature range value.

5.2.7.4.9 ERROR #

When the flow meter is not under normal condition, the code found here may provide valuable troubleshooting information.

5.2.8 SERVICE

5.2.8.1 In the "SERVICE" of secondary interface, press "FUNC" to enter the third level interface.

5.2.8.2 After entering the third level interface, press "UP" or "DOWN" to select specific setting items, and press "FUNC" to enter setting information, press "UP" or "DOWN" to change parameter, press "FUNC" to confirm, and press "ESC" to exit.

5.2.8.3 SERVICE third level interface.

The service menu contains information that is useful for service training. The contents of the menu are as follows.

5.2.8.3.1 RAW DATA

5.2.8.3.1.1 View the original data of flowmeter.

5.2.8.3.1.2 Viewable parameters include Frequency, Phase, Zero point, Filter parameters, Phase difference

5.2.8.3.1.2.1 Frequency: current vibration frequency of flow tube.

5.2.8.3.1.2.2 Phase: the current phase value of the sensor.

5.2.8.3.1.2.3 Zero point: the current zero point phase value of the sensor.

5.2.8.3.1.2.4 Filter parameters: the current filter coefficient.

5.2.8.3.1.2.5 Phase difference: phase difference = phase-zero.

5.2.8.3.2 REAL LOOP V

5.2.8.3.2.1 Display the voltage of pick coil.

5.2.8.3.2.2 The left value is upstream pickup coil voltage.

5.2.8.3.2.3 The right value is the downstream pickup coil voltage.

5.2.8.3.3 OUTPUT TEST

5.2.8.3.3.1 Simulate the output signal & test whether the flow meter output signal is right.

5.2.8.3.3.2 A total of 5 test points: 0%, 25%, 50%, 75% & 100%.

5.2.8.3.4 CLR ERROR

Clear ERROR alarm code.

5.2.8.3.5 REBOOT

Reset the flow meter with power on.

Chapter VI Communication

6.1 HART communication

6.1.1 HART Communicator introduction

- 6.1.1.1 The HART Communicator is a hand-held configuration tool, which can be used to support HART communication instruments. The instrument parameters can be read and write through the HART Communicator.
- 6.1.1.2 A dedicated DD (device description) file is necessary to ensure that the HART Communicator can be properly connected to the device.
- 6.1.1.3 The DD can be downloaded through the HART website, or you can contact Walsn or its local dealer.
- 6.1.1.4 Follow these steps you can view the device information through the HART Communicator:
 - 6.1.1.4.1 In your HART menu, select "Utility" → " Available Device Description.
 - 6.1.1.4.2 Browse the manufacturer list and select "Walsn" , and then browse the installed device description.
 - 6.1.1.4.3 If the manufacturer list does not have a Walsn, or no description of the required equipment, Please contact the HART Communicator manufacturer to install the device description, or contact Walsn or its local dealers.

6.1.2 Wire HART Communicator

- 6.1.2.1 HART Communicator needs to be connected to the flow meter's Analog Hart output channel #1.
- 6.1.2.2 HART communication supports point to point communication and multiple-point networks, please choose appropriately.
- 6.1.2.3 See figure 6-1, 6-2 for wiring

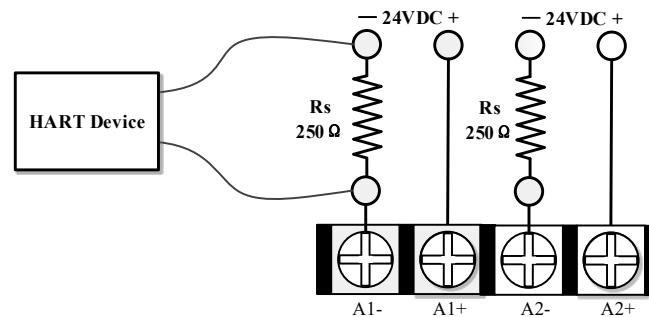

Figure 6-1 HART connection, passive current loop

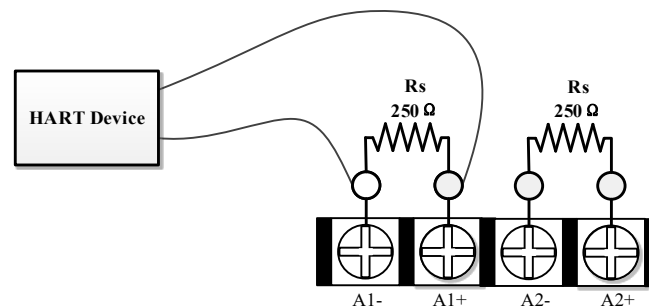

Figure 6-2 HART connection, active current loop

- 6.1.2.4 After properly wiring the HART Communicator, you can read, configure, and perform maintenance of your equipment.
- 6.1.2.5 The warning information about the device description or device status may be ignored in the connection process.

6.1.3 HART Communicator menu

The measurement and configuration information of the device is included in the HART Communicator menu.

6.1.3.1 On-Line Menu

See figure 6-3

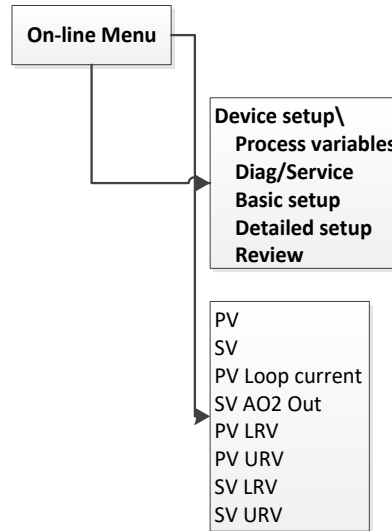

Figure 6-3 On-line Menu

6.1.3.2 Process variables

See figure 6-4

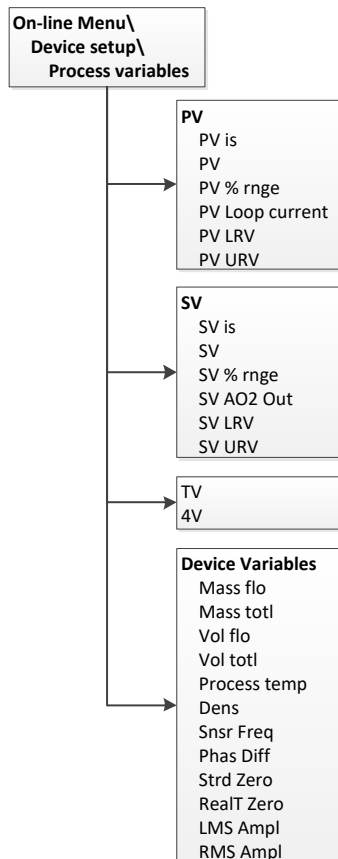

Figure 6-4 Process variables

6.1.3.3 Diag/Service

See figure 6-5

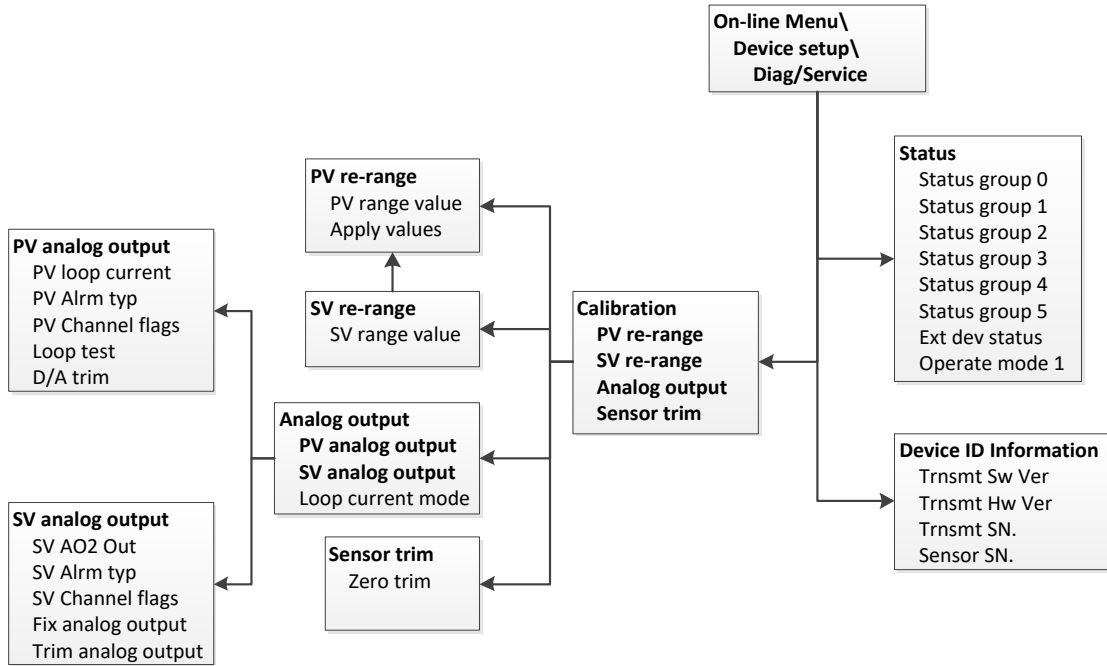

Figure 6-5 Diag/Service

6.1.3.4 Basic setup

See figure 6-6

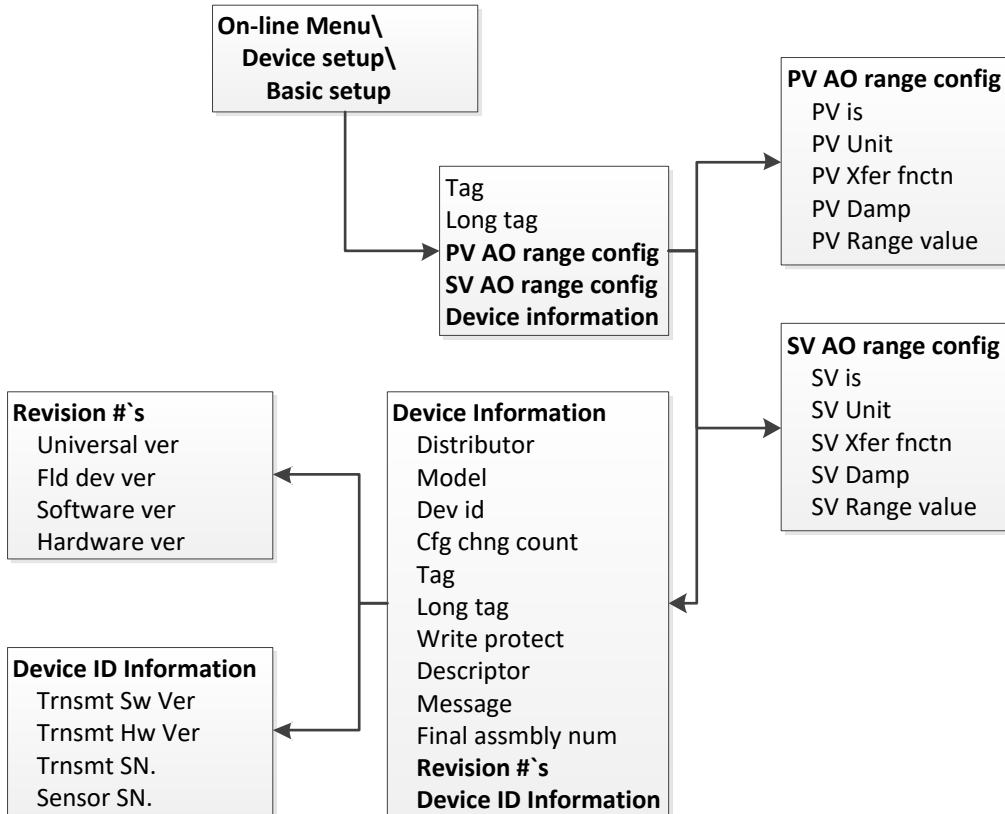

Figure 6-6 Basic setup

6.1.3.5 Detailed setup

See figure 6-7

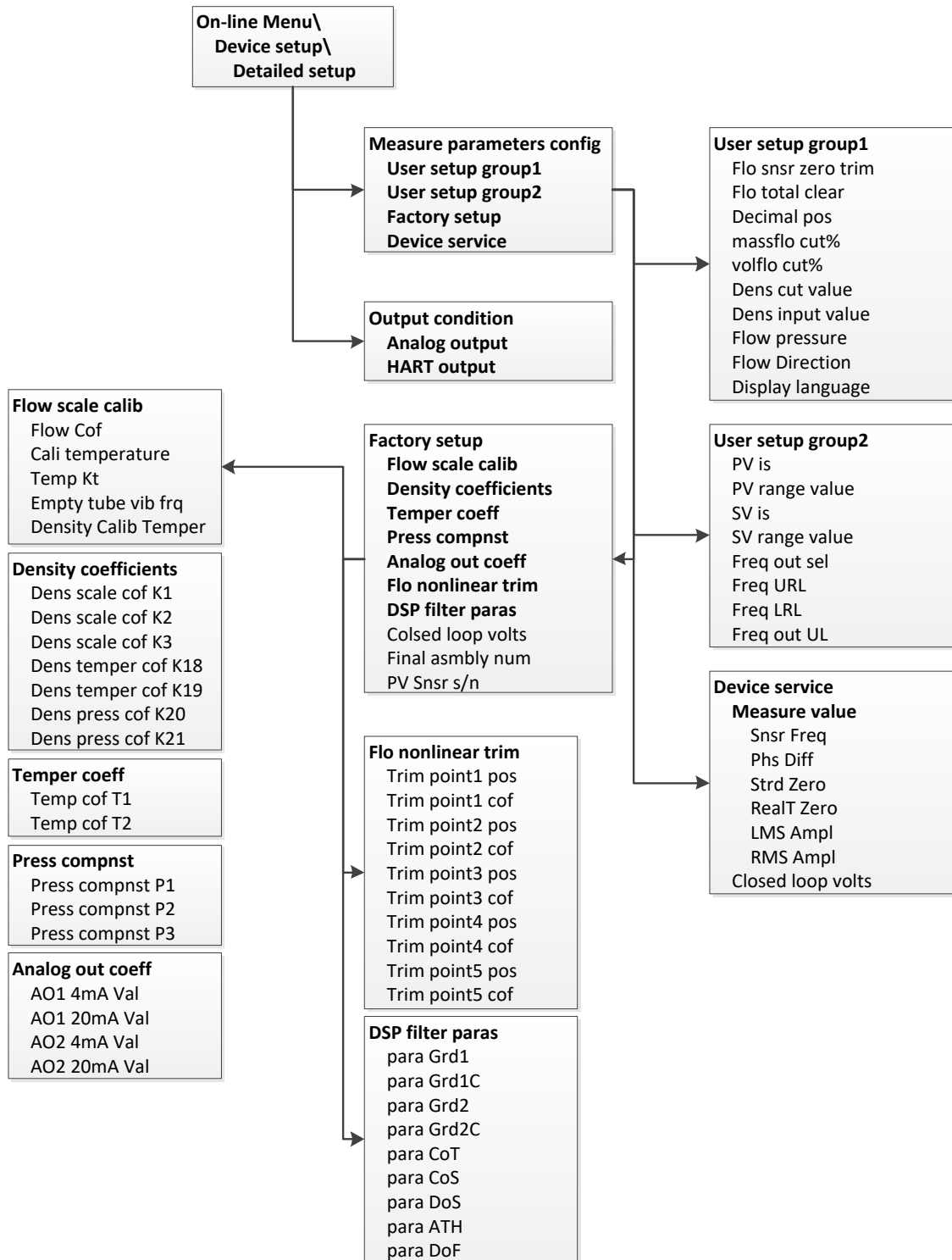

Figure 6-7 detailed setups

6.1.3.6 Review

See figure 6-8

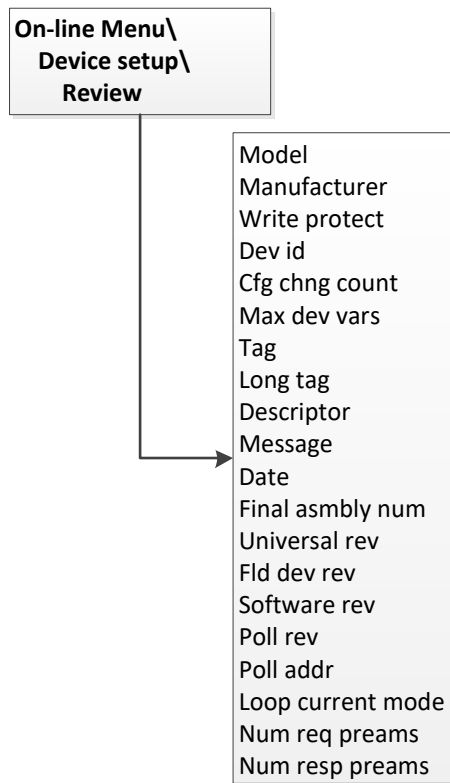

Figure 6-8 Review

6.2 Modbus RS485 communication

6.2.1 Brief introduction of Modbus RTU protocol

Walsn mass flow meters are equipped with the ability to use the Modbus communication protocol (RTU format). Users can use this feature to read and write parameters to/from the transmitter

6.2.1.1 Reading N variables

6.2.1.1.1 To send the request

Instrument address +0X03+ register start address (2 bytes, upper byte in front) + register read and write quantity 2*N (2 bytes, upper byte in front) +CRC check code (2 bytes, low-order byte in front).

6.2.1.1.2 Response

Instrument address +0X03+ the number of bytes in data 4*N (1 byte) + register data (4*N bytes, upper byte in front) +CRC parity code (2 bytes, low-order byte in front).

6.2.1.2 Writing N variables

6.2.1.2.1 To send the request

Instrument address+ function code 0x10+ initial address register (2 bytes, the high-order byte in front) + register read and write number 2*N (2 bytes, the high-order byte data in front) + the number of bytes 4*N (1 byte) + data to be written (4*N bytes, upper byte in front) + CRC check code (2 bytes, the low order byte in front).

6.2.1.2.2 Response

Instrument address+ function code 0x10+ initial address register (2 bytes, the high-order byte in front) + register read and write number 2*N (2 bytes, the

high-order byte data in front) +CRC check code (2 bytes, the low order byte in front).

6.2.2 Parameter address and default value

See table 6-1

Table 6-1 Parameter address and default value

No.	Address	Name	Notes	Default type
1	1024	Mass flow rate		Read Only
2	1026	Mass total L	Total mass= L+H*1000000	Read Only
3	1028	Mass total H		Read Only
4	1030	Volume flow rate		Read Only
5	1032	Volume L	Total mass = L+H*1000000	Read Only
6	1034	Volume H		Read Only
7	1036	Process temperature		Read Only
8	1038	Process density		Read Only
9	1040	Tube frequency	Default Hz	Read Only
10	1042	Phase difference	Default us	Read Only
11	1044	Original zero point	Default us	Read Only
12	1046	Real time zero point	Default us	Read Only
13	1048	Left pick up coil amplitude	Default mV	Read Only
14	1050	Right pick up coil amplitude	Default mV	Read Only
15	1052	Mass flow unit	enum, 0~14	Read and Write/5
16	1054	Mass total unit	enum, 0~3	Read and Write /1
17	1056	Volumetric flow rate unit	enum, 0~14	Read and Write /5
18	1058	Volume unit	enum, 0~3	Read and Write /2
19	1060	Process temperature unit	enum, 0~1	Read and Write /0
20	1062	Process density unit	enum, 0~5	Read and Write /0
21	1064	Software version		Read Only
22	1066	Transmitter model		
23	1068	Transmitter SN.	Write access forbidden	Read Only
24	1070	Sensor SN.	Write access forbidden	Read Only
25	1072	Clearance of total value	Read back to 1	Write 0
26	1074	Zero point calibration	Read back to 1	Write 0
27	1076	Refresh damping	0~60.0s	Read and Write /0.5
28	1078	Decimal digits	0~3	Read and Write

				/3
29	1080	Mass flow cut off ratio	0~50.00%	Read and Write /1
30	1082	Volume flow cut off ratio	0~50.00%	Read and Write /1
31	1084	Density cut off value	0 g/cm ³ ~1.0000g/cm ³	Read and Write /0.005
32	1086	Input density value	0g/L~3000.0000g/L	Read and Write /0
33	1088	Process pressure	0MPa~99.99MPa	Read and Write /4
34	1090	Flow direction	0~3	Read and Write /0
35	1092	Language option	0~1	Read and Write /0
36	1094	Max. mass	0~99999	Read and Write /1000
37	1096	Min. mass	0~99999	Read and Write /0
38	1098	Mass unit	0~2	Read and Write /1
39	1100	Max. volume	0~99999	Read and Write /1000
40	1102	Min. volume	0~99999	Read and Write /0
41	1104	Volume unit	0~2	Read and Write /1
42	1106	Max. density	0~3000	Read and Write /3000
43	1108	Min. density	0~3000	Read and Write /0
44	1110	Density unit	0	Read and Write /0
45	1112	Max. temperature	-200~400	Read and Write /180
46	1114	Min. temperature	-200~400	Read and Write /-50
47	1116	Temperature unit	0	Read and Write /0
48	1118	Configuration of current output-CH1	0~3	Read and Write /0
49	1120	Configuration of current output -CH2	0~3	Read and Write /1
50	1122	Max. Configuration of current output -CH1	0~99999	Read and Write /1000
51	1124	Min. Configuration of current output -CH1	0~99999	Read and Write /0
52	1126	Max. Configuration of current output -CH2	0~99999	Read and Write /1000
53	1128	Min. Configuration of current output - CH2	0~99999	Read and Write /0
54	1130	Configuration of current output unit-CH1	With the process variable unit	Read Only
55	1132	Configuration of current output	With the process variable unit	Read Only

		unit-CH2		
56	1134	Configuration of frequency output	0~1	Read and Write /0
57	1136	Max. Configuration of frequency output	0~99999	Read and Write /1000
58	1138	Min. Configuration of frequency output	0~99999	Read and Write /0
59	1140	Configuration of frequency output unit	Default kHz	Read and Write /0
60	1142	Max. output frequency	1~10	Read and Write /10
61	1144	Flow gain coefficient	0~10000.000	Read and Write /82.0
62	1146	Calibrated temperature	-50°C~100°C	Read and Write /22.5
63	1148	Gain temperature Kt	-999.999~999.999	Read and Write /-51.08
64	1150	Vibration frequency of empty pipe	50Hz~500Hz	Read and Write /140.0
65	1152	Density calibrated temperature	-50.0°C~100.0°C	Read and Write /22.5
66	1154	Density gain K1	-999.999~999.999	Read and Write /1.31
67	1156	Density gain K2	-999.999~999.999	Read and Write /0
68	1158	Density gain K3	-999.999~999.999	Read and Write /0
69	1160	Density temperatureK18	-999.999~999.999	Read and Write /0
70	1162	Density temperature K19	-999.999~999.999	Read and Write /0
71	1164	Density pressure K20	-999.999~999.999	Read and Write /0
72	1166	Density pressure K21	-999.999~999.999	Read and Write /0
73	1168	Pressure compensation coefficient P1	-999.999~999.999	Read and Write /0
74	1170	Pressure compensation coefficient P2	-999.999~999.999	Read and Write /0
75	1172	Pressure compensation coefficient P3	-999.999~999.999	Read and Write /0
76	1174	AO1-4mA calibration value	2mA~6.0000mA	Read and Write /4.0
77	1176	AO1-20mA calibration value	18mA~22.0000mA	Read and Write /20.0
78	1178	AO2-4mA calibration value	2mA~6.0000mA	Read and Write /4.0
79	1180	AO2-20mA calibration value	18mA~22.0000mA	Read and Write /20.0
80	1182	Calibrated Temperature coefficient T1	0~5.000	Read and Write /1.0
81	1184	Calibrated Temperature coefficient T2	0~5.000	Read and Write /0

82	1186	Set loop voltage	10mV~500mV	Read and Write /160
83	1188	Correction point 1 ratio	0%~150%	Read and Write /0
84	1190	Correction point 2 ratio	0%~150%	Read and Write /0
85	1192	Correction point 3 ratio	0%~150%	Read and Write /0
86	1194	Correction point 4 ratio	0%~150%	Read and Write /0
87	1196	Correction point 5 ratio	0%~150%	Read and Write /0
88	1198	Correction point 1 coefficient	-50.00~50.00	Read and Write /0
89	1200	Correction point 2 coefficient	-50.00~50.00	Read and Write /0
90	1202	Correction point 3 coefficient	-50.00~50.00	Read and Write /0
91	1204	Correction point 4 coefficient	-50.00~50.00	Read and Write /0
92	1206	Correction point 5 coefficient	-50.00~50.00	Read and Write /0
93	1208	Current loop output mode	0~1	Read and Write /1
94	1210	HART Polling addr	0~63	Read and Write /0
95	1212	Current loop output -CH1	0mA~22.0000mA	Read and Write /0
96	1214	Current loop output-CH2	0mA~22.0000mA	Read and Write /0
97	1216	Current loop output	0~3	Read Only
98	1218	Grd1	0~1.000	Read and Write /0.015
99	1220	Grd1C	0~1.000	Read and Write /1.000
100	1222	Grd2	0~1.000	Read and Write /0.008
101	1224	Grd2C	0~1.000	Read and Write /0.700
102	1226	CoT	0~1.000	Read and Write /0.050
103	1228	CoS	0~1.000	Read and Write /0.005
104	1230	DoS	0~1.000	Read and Write /0.020
105	1232	ATH	0~1.000	Read and Write /0.090
106	1234	DoF	0~1.000	Read and Write /0.001
107	1236	Comm password	0~9999	Write Only /5124
108	1238	Comm password reset	0~9999	Write Only
109	1240	Double component calculation	0~5	Read and Write /0

110	1242	Double component calculation temp. pt.1	-50~400	Read and Write /0.00
111	1244	Double component calculation temp. pt.2	-50~400	Read and Write /0.00
112	1246	Double component calculation temp. pt.3	-50~400	Read and Write /0.00
113	1248	Double component calculation temp. pt.4	-50~400	Read and Write /0.00
114	1250	Double component calculation temp. pt.5	-50~400	Read and Write /0.00
115	1252	Group A temp. pt.1 density	0~3.0000	Read and Write /0
116	1254	Group A temp. pt.2 density	0~3.0000	Read and Write /0
117	1256	Group A temp. pt.3 density	0~3.0000	Read and Write /0
118	1258	Group A temp. pt.4 density	0~3.0000	Read and Write /0
119	1260	Group A temp. pt.5 density	0~3.0000	Read and Write /0
120	1262	Group B temp. pt.1 density	0~3.0000	Read and Write /0
121	1264	Group B temp. pt.2 density	0~3.0000	Read and Write /0
122	1266	Group B temp. pt.3 density	0~3.0000	Read and Write /0
123	1268	Group B temp. pt.4 density	0~3.0000	Read and Write /0
124	1270	Group B temp. pt.5 density	0~3.0000	Read and Write /0
125	1272	Group A volume ratio	0~100.00	Read Only
126	1274	Group A mass ratio	0~100.00	Read Only
127	1276	Error code	Bit0~Bit4	Read and Write /0



6.2.2.1 Each register has 4 bytes, occupying two addresses (low address addressing), and data transfer using 32 single precision floating point number (high byte in front).

6.2.2.2 Grey shaded parameters (23~24, 36~47,61~106) are Manufacturer parameters, which have been optimized before delivery, do not modify these values! Parameters written in red text (23~24,42~47,76~81,93,95~96,107~108) t can be Accessed and modified only through Modbus communication, and are not available through the standard user interface.

6.2.3 Configuration

6.2.3.1 Mass flow unit

The codes for the various mass flow rate units are defined in table 6-2.

Table 6-2 mass flow rate units

Code	0	1	2	3	4	5	6	7
Unit	g/s	g/min	g/h	kg/s	kg/min	kg/h	kg/day	t/s
Code	8	9	10	11	12	13	14	
Unit	t/min	t/h	t/day	lb/s	lb/min	lb/h	lb/day	

6.2.3.2 Volumetric flow unit

The codes for the various volumetric flow rates units are defined in table 6-3.

Table 6-3 volumetric flow unit

Code	0	1	2	3	4	5	6	7
Unit	ml/s	ml/min	ml/h	L/s	L/min	L/h	L/day	m3/s
Code	8	9	10	11	12	13	14	
Unit	m3/min	m3/h	m3/day	Gal/s	Gal/min	Gal/h	Gal/day	

6.2.3.3 Totalized mass unit

The codes for the various totalized mass are defined in table 6-4.

Table 6-4 totalized mass unit

Code	0	1	2	3
Unit	g	Kg	t	lb

6.2.3.4 Totalized volume unit

The codes for the various totalized volume are defined in table 6-5.

Table 6-5 totalized volume unit

Code	0	1	2	3
Unit	ml	L	m3	Gal

6.2.3.5 Density unit

The codes for density units are defined in table 6-6.

Table 6-6 density unit

Code	0	1	2	3	4	5
Unit	g/cm3	g/L	g/ml	kg/L	kg/m3	lb/Gal

6.2.3.6 Temperature unit

The codes for the various process temperature units are defined in table 6-7.

See figure 6-7 medium temperature unit

Code	0	1
Unit	°C	°F

6.2.3.7 Flow direction

The codes for flow direction configurations are defined in table 6-8.

Table 6-8 flow direction

Code	0	1	2	3
Direction	+	-	+/-	Abs. value

6.2.3.8 Display Language

The codes for languages are defined in table 6-9.

Table 6-9 Display Language

Code	0	1
Language	Chinese	English

6.2.3.9 Mass flow range unit

The codes for mass range units are defined in table 6-10.

Table 6-10 mass range unit

Code	0	1	2
------	---	---	---

Unit	t/h	kg/h	g/h
------	-----	------	-----

6.2.3.10 Volume flow range unit

The codes for volume range units are defined in table 6-11.

Table 6-11 volume range unit

Code	0	1	2
Unit	m ³ /h	L/h	mL/h

6.2.3.11 Density range unit

The code for density range unit is defined in table figure 6-12.

Table 6-12 Density range unit

Code	0
Unit	kg/m ³

6.2.3.12 Temperature range unit

The code for temperature range unit is defined in table 6-13.

Table 6-13 temperature range unit

Code	0
Unit	°C

6.2.3.13 Configuration of current output mode -CH1/-CH2

The codes for configuring which measurement is output on each of the analog output loops are defined in table 6-14.

Table 6-14 Configuration of current output mode -CH1/-CH2

Code	0	1	2	3
Mode	Mass flow	Volumetric flow	Medium density	Medium temperature

6.2.3.14 Configuration of frequency output

The codes for configuring which measurement is output on the frequency output are defined in table 6-15

Table 6-15 Configuration of frequency output

Code	0	1
Mode	Mass flow	Volume flow

6.2.3.15 Current loop output mode

The codes for configuring the current loop mode are defined in table 6-16.

Table 6-16 current loop output mode

Code	0	1
Mode	no	enable

6.2.3.16 Fixed output current

The codes for enabling fixed current output are defined in table 6-17.

Table 6-17 fixed output current

Code	0	1	2	3
Meaning	normal	CH1 fixed	CH2 fixed	CH1 and CH2 fixed

6.2.3.17 Error code

The codes used for troubleshooting the flow meter are defined in table 6-18.

Table 6-18 error code

Code	Bit4	Bit3	Bit2	Bit1	Bit0
Error	Abnormal sensor temperature	Abnormal sensor frequency	Abnormal sensor amplitude	Over 20% of max. Frequency range	Zero warning

6.2.3.17.1 Error code maintenance

Once the error code is set, it will not be cleared until the instrument is reset, or it is manually cleared using one of the three following methods.

- 6.2.3.17.1.1 Enter "SERVICE" → "CLR ERROR", the fault code will be cleared, but will reappear if the issue persists.
- 6.2.3.17.1.2 Write the fault code clear code "60000" to Modbus address "1276". the fault code will be cleared, but will reappear if the issue persists.
- 6.2.3.17.1.3 Write the fault code shielding code (set the position to be shielded as 1) to Modbus address "1276". the fault code will be blocked until the shielding code is removed.

6.2.3.18 Cutoff ratio of mass flow / volume flow

Once the measured mass (volume) flow rate is less than the low flow cutoff proportion, the output will drive to Zero.

6.2.3.19 Internal calibration of 4mA & 20mA (AO1-AO2)

Analog output can be calibrated as follows:

- 6.2.3.19.1 Fixed instrument output 4mA, measured analog output value, denoted as x1.
- 6.2.3.19.2 Fixed instrument output 20mA, measured analog output value, denoted as x2.
- 6.2.3.19.3 X1 and X2 are written to the corresponding parameters.

6.2.3.20 Current output value-CH1/CH2

When read, this will contain the actual output current of corresponding current loop channel. When written to, if the written value is between 4mA to 20mA, then the corresponding current loop channel will output the written value; if the written value is 0, then the corresponding current loop output will return to outputting the assigned process variable.

Chapter VII Troubleshooting



7.1 Overview

Please read the guide carefully and understand the installation and use of the flow meter. Make site diagnosis as far as possible, and make full consideration of the response of the instrument cases of process flow and non-flow, as well as the influence of the state of the medium and the other factors of the environment, so as to ensure not to ignore any symptoms and causes.

7.2 Product appearance inspection

Please check the following carefully. Any question, please call Walsn directly or your local distributor.

7.2.1 Not dent

7.2.2 No strange sounds while shaking





7.2.3 No defacing of the front glass cover

7.2.4 No shedding in logo nameplate.

7.3 Status information

The transmitter display may show symbols which can help identify problems with the flow meter, these symbols and the solutions are defined in table 8-1.

Table 8-1 status information table

Symbol	Typical Cause of Fault	Solution
	<ul style="list-style-type: none"> <input type="checkbox"/> Over upper range limit. <input type="checkbox"/> Valid numbers cannot be fully displayed. 	<ul style="list-style-type: none"> <input type="checkbox"/> Use a bigger line size flow mete <input type="checkbox"/> Select a bigger unit
	<ul style="list-style-type: none"> <input type="checkbox"/> Filtering coefficient is less than 0.21 (meet the zero condition), and the absolute value of the phase difference is greater than 0.020us. 	<ul style="list-style-type: none"> <input type="checkbox"/> Zero calibration is necessary.
	<ul style="list-style-type: none"> <input type="checkbox"/> Filtering coefficient is less than 0.21 (meet the zero condition), and the absolute value of the phase difference is between 0.020us and 0.015us. 	<ul style="list-style-type: none"> <input type="checkbox"/> Zero calibration is recommended
	<ul style="list-style-type: none"> <input type="checkbox"/> Touch keys are locked 	<ul style="list-style-type: none"> <input type="checkbox"/> Simultaneously press "up" and "function" keys for 5s to unlock
	<ul style="list-style-type: none"> <input type="checkbox"/> Touch keys are 	<ul style="list-style-type: none"> <input type="checkbox"/> Touch keys are will lock automatically after 30s of inactivity.

7.4 Troubleshooting and solution

7.4.1 Flow meter does not run

The typical causes of, and solutions to, this problem are laid out in table 8-2.

Table 8-2 Troubleshooting causes and solutions of flow meter not running

Problem Description	Possible Causes	Solution
No display	<ul style="list-style-type: none"> <input type="checkbox"/> Power supply fault <input type="checkbox"/> Transmitter fault 	<ul style="list-style-type: none"> <input type="checkbox"/> Check transmitter power supply and wiring. <input type="checkbox"/> Please contact Walsn or local distributor.
Touch keys are unresponsive.	<ul style="list-style-type: none"> <input type="checkbox"/> Touch keys locked. <input type="checkbox"/> Defaced glass of transmitter. <input type="checkbox"/> Transmitter front cover is loose. 	<ul style="list-style-type: none"> <input type="checkbox"/> Simultaneously press "up" and "function" keys for 5s. <input type="checkbox"/> Clean transmitter front cover glass <input type="checkbox"/> Tighten & reboot flow meter
No tube vibration	<ul style="list-style-type: none"> <input type="checkbox"/> Faulty wiring between transmitter and sensor. <input type="checkbox"/> Flow meter fault 	<ul style="list-style-type: none"> <input type="checkbox"/> Verify the connection between the sensor and the transmitter. <input type="checkbox"/> Please contact Walsn or local distributor.

7.4.2 Flow measurement problems

The typical causes of, and solutions to, this problem are laid out in table 8-3

Table 8-3, flow measurement problem

Problem description	Possible causes of Troubleshooting	Solution
<ul style="list-style-type: none"> <input type="checkbox"/> Flow meter display a steady non-zero flow while no flow 	<ul style="list-style-type: none"> <input type="checkbox"/> External forces on flow meter <input type="checkbox"/> Valve open or leakage <input type="checkbox"/> Sensor zero drift <input type="checkbox"/> Transmitter incorrectly configured for sensor 	<ul style="list-style-type: none"> <input type="checkbox"/> Check for external forces on flow meter (e.g. pipe eccentricity, flow meter enclosure bearing weight) <input type="checkbox"/> Ensure valves are properly seated <input type="checkbox"/> Zero calibration <input type="checkbox"/> Check sensor and transmitter serial numbers and calibration parameters against records
<ul style="list-style-type: none"> <input type="checkbox"/> Flow meter display a fluctuant flow while no flow 	<ul style="list-style-type: none"> <input type="checkbox"/> Wiring problems <input type="checkbox"/> Radio frequency interference <input type="checkbox"/> Valve open or leakage <input type="checkbox"/> Slug flow <input type="checkbox"/> Flow tube blocking or coating. <input type="checkbox"/> Vibration interference or pipe harmonic resonance <input type="checkbox"/> Wrong flow unit or low flow cutoff value <input type="checkbox"/> Mounting forces on flow meter 	<ul style="list-style-type: none"> <input type="checkbox"/> Check drive gain and detect voltage <input type="checkbox"/> Verify grounding of the sensor and transmitter <input type="checkbox"/> Check the moisture of junction box <input type="checkbox"/> Investigate possible sources of radio frequency interference <input type="checkbox"/> Ensure valves are properly seated <input type="checkbox"/> Purge flow tube <input type="checkbox"/> Ensure flowmeter is isolated

		<p>from sources of vibration (even other flowmeters)</p> <ul style="list-style-type: none"> <input type="checkbox"/> Adjust low flow cutoff and choose a suitable flow unit <input type="checkbox"/> Check for external forces on flow meter (e.g. pipe eccentricity, flow meter enclosure bearing weight) <input type="checkbox"/> Call Walsn
<ul style="list-style-type: none"> <input type="checkbox"/> Flow meter display a fluctuant flow while there is a stable flow 	<ul style="list-style-type: none"> <input type="checkbox"/> Wiring problems <input type="checkbox"/> Radio frequency interference <input type="checkbox"/> Slug flow <input type="checkbox"/> Two-phase flow <input type="checkbox"/> Flow tube blocking or coating <input type="checkbox"/> Pipe vibration <input type="checkbox"/> Output wiring problem <input type="checkbox"/> Receiving equipment problem 	<ul style="list-style-type: none"> <input type="checkbox"/> Check drive gain and detect voltage <input type="checkbox"/> Verify grounding of the sensor and transmitter <input type="checkbox"/> Check the moisture of junction box <input type="checkbox"/> Investigate possible sources of radio frequency interference <input type="checkbox"/> Check if there is two-phase flow, tube coating or tube damage. <input type="checkbox"/> Purge flow tube <input type="checkbox"/> Ensure flowmeter is isolated from sources of vibration (even other flowmeters) <input type="checkbox"/> Ensure that the pipeline is properly supported <input type="checkbox"/> Call Walsn
<ul style="list-style-type: none"> <input type="checkbox"/> Measured flow or volume is not accurate 	<ul style="list-style-type: none"> <input type="checkbox"/> Wiring problems <input type="checkbox"/> Wrong flow unit <input type="checkbox"/> Flow calibration coefficient error <input type="checkbox"/> Density calibration coefficient error <input type="checkbox"/> Slug flow <input type="checkbox"/> Unexpected condensation in flow tube <input type="checkbox"/> Receiving equipment problem <input type="checkbox"/> Filter coefficient is too large 	<ul style="list-style-type: none"> <input type="checkbox"/> Verify wiring and grounding of the sensor and transmitter <input type="checkbox"/> Check the resistance of the sensor coil and whether it is short connected with the casing. <input type="checkbox"/> Choose a suitable flow unit <input type="checkbox"/> Verify that coefficients match the data on the nameplate of the sensor <input type="checkbox"/> Zero calibration <input type="checkbox"/> Ensure slug flow does not appear <input type="checkbox"/> Ensure sensor is oriented as recommended <input type="checkbox"/> Adjust small filter coefficient

		<ul style="list-style-type: none"> ☐ Replace the core processor or transmitter.
<ul style="list-style-type: none"> ☐ No flow output while non-zero flow ☐ Current loop or frequency output is zero 	<ul style="list-style-type: none"> ☐ Flow direction error ☐ Low flow cutoff set too high ☐ Zero calibration error ☐ Flow coefficient error ☐ Closed loop control voltage is too low ☐ Sensor failure ☐ Configuration error in current loop or frequency 	<ul style="list-style-type: none"> ☐ Confirm the installation direction, and configuration of flow direction ☐ Choose appropriate low flow cutoff ☐ Zero calibration ☐ Verify flow coefficient ☐ Ensure closed loop control voltage is appropriate ☐ Avoid two phase flow ☐ Verify configuration of current loop and frequency setting
<ul style="list-style-type: none"> ☐ Zero calibration failure, zero flow instability. ☐ Vibration amplitude is small and unstable (DN1~DN5: amplitude of vibration < 40mV; DN15~DN250: vibration amplitude < 80mV). ☐ The flow meter output is obviously wrong, and the measurement data is not stable. 	<ul style="list-style-type: none"> ☐ Flow during zero calibration ☐ External forces on flowmeter ☐ Vibration interference or pipe harmonic resonance ☐ Radio frequency interference ☐ Wiring Problems ☐ Sensor fault 	<ul style="list-style-type: none"> ☐ Ensure no flow during zero flow calibration ☐ Ensure flow meter is installed per the installation section ☐ Ensure flowmeter is isolated from sources of vibration (even other flowmeters) ☐ Investigate sources of radio frequency interference ☐ Verify wiring and confirm the reliability grounding of the sensor and transmitter ☐ Call Walsn

7.4.3 Density measurement problem

The typical causes of, and solutions to, this problem are laid out in table 8-4

Table 8-4 Density measurement problem

Problem description	Possible causes of Troubleshooting	Solution
<ul style="list-style-type: none"> ☐ Density output error 	<ul style="list-style-type: none"> ☐ Wiring problems ☐ Density calibration coefficient error ☐ Slug flow ☐ Flow tube coating ☐ Pipe vibration ☐ Sensor physical characteristic parameters changed 	<ul style="list-style-type: none"> ☐ Verify wiring and grounding ☐ Verify that all parameters match the data on the nameplate of the sensor ☐ Avoid slug flow ☐ Purge flow tube ☐ Ensure flowmeter is isolated from sources of vibration (even other flowmeters) ☐ Change the installation location
<ul style="list-style-type: none"> ☐ Density output 	<ul style="list-style-type: none"> ☐ Density coefficient error 	<ul style="list-style-type: none"> ☐ Verify that all parameters match the

is extremely high.	<ul style="list-style-type: none"> <input type="checkbox"/> Error in temperature measurement <input type="checkbox"/> Flow tube coating <input type="checkbox"/> Flow pipe erosion or corrosion 	<ul style="list-style-type: none"> data on the nameplate of the sensor <input type="checkbox"/> Purge flow tube <input type="checkbox"/> Inspect flow tube for obstruction/damage/coating
<input type="checkbox"/> Density output is extremely low.	<ul style="list-style-type: none"> <input type="checkbox"/> Density coefficient error <input type="checkbox"/> Slug flow <input type="checkbox"/> Wear/corrosion. 	<ul style="list-style-type: none"> <input type="checkbox"/> Verify that all parameters match the data on the nameplate of the sensor <input type="checkbox"/> Eliminate slug flow <input type="checkbox"/> Inspect flow tube for damage/wear

7.4.4 Temperature measurement problem

The typical causes of, and solutions to, this problem are laid out in table 8-5

Table 8-5 Temperature measurement problem

Problem description	Possible causes of Troubleshooting	Solution
<input type="checkbox"/> Temperature output error	<ul style="list-style-type: none"> <input type="checkbox"/> Wiring problem <input type="checkbox"/> temperature <input type="checkbox"/> Temperature coefficient error <input type="checkbox"/> Temperature sensor damaged 	<ul style="list-style-type: none"> <input type="checkbox"/> Check moisture of junction boxes <input type="checkbox"/> Verify wiring of the sensor and transmitter <input type="checkbox"/> Verify temperature calibration.

7.4.5 Current loop output problem

The typical causes of, and solutions to, this problem are laid out in table 8-6

Table 8-6 Current loop output problem

Problem description	Possible causes of Troubleshooting	Solution
<input type="checkbox"/> No output	<ul style="list-style-type: none"> <input type="checkbox"/> Wiring problem. <input type="checkbox"/> Error in current loop configuration. <input type="checkbox"/> Circuit fault. 	<ul style="list-style-type: none"> <input type="checkbox"/> Check the power supply and power supply connection. <input type="checkbox"/> Check current output connection. <input type="checkbox"/> Confirm current loop is active or passive, passive current loop needs external power supply. <input type="checkbox"/> Call Walsn or local distributor.
<input type="checkbox"/> Error in current loop output value.	<ul style="list-style-type: none"> <input type="checkbox"/> Configuration information is incorrect. <input type="checkbox"/> Circuit fault. <input type="checkbox"/> Current loop calibration parameters are incorrect. 	<ul style="list-style-type: none"> <input type="checkbox"/> Check configuration information: flow / density / temperature. <input type="checkbox"/> Call Walsn or local distributor.
<input type="checkbox"/> Constant current loop output.	<ul style="list-style-type: none"> <input type="checkbox"/> Configuration information is incorrect. <input type="checkbox"/> Zero calibration failure. <input type="checkbox"/> Exceed the upper range value: Flow over range, density over 3000g/cm³. <input type="checkbox"/> Exceed the lower limit: The 	<ul style="list-style-type: none"> <input type="checkbox"/> Check configuration information: flow / density / temperature <input type="checkbox"/> Check HART address and loop current mode. <input type="checkbox"/> Try again Zero calibration <input type="checkbox"/> Replace Flow meter with larger line size.

	measured value is less than the low cutoff value.	<input type="checkbox"/> Check the low cutoff level.
--	---	--

7.4.6 Frequency output problem

The typical causes of, and solutions to, this problem are laid out in table 8-7

Table 8-7 Frequency output problem

Problem description	Possible causes of Troubleshooting	Solution
<input type="checkbox"/> No frequency output.	<ul style="list-style-type: none"> <input type="checkbox"/> The process condition is lower than the low cutoff level. <input type="checkbox"/> Slug flow. <input type="checkbox"/> Opposite direction. <input type="checkbox"/> Frequency receiving equipment fault. <input type="checkbox"/> The output voltage is not compatible with the receiving device. <input type="checkbox"/> Wiring problem. <input type="checkbox"/> Output circuit fault. 	<ul style="list-style-type: none"> <input type="checkbox"/> Configure low cutoff level. <input type="checkbox"/> Avoid slug flow. <input type="checkbox"/> Check flow direction. <input type="checkbox"/> Verify whether the receiving equipment is faulty. <input type="checkbox"/> Verify the input voltage of the receiving device. <input type="checkbox"/> Verify the whole wiring. <input type="checkbox"/> Call Walsn or local distributor.
<input type="checkbox"/> Frequency output error	<ul style="list-style-type: none"> <input type="checkbox"/> Output voltage fault. <input type="checkbox"/> Error in the frequency upper range value configuration <input type="checkbox"/> Flow overflow. 	<ul style="list-style-type: none"> <input type="checkbox"/> Verify the input level of the receiving device. <input type="checkbox"/> Check the upper range value of frequency output configuration. <input type="checkbox"/> If the flow rate is 25% higher than the full range, then the maximum frequency outputs can up to 12.5 kHz.
<input type="checkbox"/> Frequency output instability.	<input type="checkbox"/> (RFI)External radio frequency interference.	<input type="checkbox"/> Check if there is radio frequency interference.

7.5 Inspection items and methods

7.5.1 Check the power supply

If the power cable is damaged or incorrect wiring, the flow meter will not work properly.

7.5.1.1 Before checking the power cable, disconnect the power supply.

In explosive zone, wait at least 5 minutes after power off while you remove the transmitter's covers.

7.5.1.2 Ensure the power supply used appropriate fuses. An incorrect fuse will limit the current to the transmitter and can cause it to fail to initialize.

7.5.1.3 Make sure that the power supply is connected to the correct terminal.

7.5.1.4 Confirm that the power cable is in good contact.

7.5.1.5 Make sure the power supply is compatible with the label in the transmitter housing.

7.5.1.6 Power on the transmitter again.

7.5.1.7 In hazardous area, DON'T power on while the transmitter's covers OPEN.

7.5.1.8 Please check the voltage of the transmitter power supply terminal, which should be in the specified range.

7.5.2 Check the wiring between the sensor and the transmitter.





If the wiring between the sensor and the transmitter is not properly connected or the connection is damaged, the flow meter will not work properly.

7.5.2.1 Keep power off before opening the junction boxes.

In explosive zone, wait at least 5 minutes after power off while you remove the transmitter's covers.

7.5.2.2 Please strictly follow the guide for wiring.

7.5.2.3 Make sure all wiring is tightened.

7.5.3 Check grounding

Reliable grounding must be ensured of sensor and transmitter, the grounding resistance $\leq 4\Omega$.

Poor grounding might lead to poor measurement performance.

7.5.4 Check if there is radio frequency interference (RFI)

The output of the transmitter may be affected by radio frequency interference (RFI). Possible sources of RFI include Radio emission source or large transformer, pump or motor that can produce huge magnetic field. RFI can be reduced by a variety of methods.

7.5.4.1 Remove RFI source.

7.5.4.2 Moving transmitter.

7.5.4.3 Using shielded cable for frequency or discrete output.

7.5.4.4 It is unnecessary for all shielding connection.

7.5.5 Coil detection

For remote flow meter, with a digital multi-meter you can easily test the coil resistance through the junction box.

7.5.5.1 Remove the cable between sensor & transmitter

7.5.5.2 Test the resistance between Pin3/Pin4 (L+/GND) & Pin5/Pin4(R+/GND). The value difference should be less than $\pm 2\Omega$.

7.5.5.3 Test the resistance between Pin1/Pin2 (D+/D-). Short or open means faulty coil.



Chapter VIII Daily Care and Maintenance

8.1 Flowmeter Inspection

8.1.1 Daily inspection

Routing inspection is enough for Walsn mass flowmeter.

8.1.2 Inspection items and period

The Inspection period in table 9-1 is the general standard. Determine the appropriate period of inspection based on site situation and environment.

Table 9-1 Flow meter check item

Items for inspection	Inspection period	Inspection and maintenance Essentials	Remarks
Transmitter display	At any time	Visual	Pay attention to all kinds of alarm information
Vibration and sound	Every day	Judge according to the sense of hearing	Whether there is a change compared with the usual
Appearance check	According to the status of oil pollution	Cleaning with non-woven wipe or compressed air	Please keep the flow meter appearance clean
Fasteners	According to the use of the situation	the fasteners of flange, junction box, transmitter housing cover & conduit gland	Please fasten
Seal ring	According to the use of the situation	the seal rings of flange connection, transmitter housing cover, junction box & conduit	Replace rubber ring Operation after power off
Annual inspection	Once year	calibration if necessary	Adjust the characteristic parameter according to the result of the measurement
Comprehensive inspection	At least once in 5 years	Please contact the manufacturer	Please do not disassemble or clean the flow meter voluntarily

8.2 Flow meter storage

8.2.1 The flow meter should be stored according to the environmental conditions detailed in table 9-2.

Table 9-2 Environmental requirements for the storage of flow meter

Environmental characteristics	Requirements	Remarks
Environment temperature	-40°C ~ +70°C	For long-term storage, the temperature should be lower than 30°C , avoid deterioration of capacitance characteristics, avoid storage in such environment as condensation and freezing caused by temperature variation.
Environment humidity	5%RH ~ 95%RH	Plastic film sealing , desiccant or other measures
Other conditions	Being not subject to direct sunlight, no dust, no corrosive, no flammable gas, oil mist, steam, water dripping, vibration, less salt	

8.2.2 Long term storage

To prevent the failure of internal electronic components it is recommended to power up the transmitter every 6 months for at least half an hour.

8.2.3 Draining

To prolonging the service life, any liquid inside the sensor tube should be emptied to prevent damage/corrosion.

8.3 Flowmeter warranty

8.3.1 Warranty period

In the normal use of the flowmeter, the warranty period is 18 months after delivery or within 12 months after installation (whichever is the first), if exceeding the warranty period, the appropriate maintenance costs will be charged.

8.3.2 Special terms

Even in the warranty period, such occurrence as the followings, we will also charge a certain maintenance costs.

8.3.2.1 Equipment damage caused by assembly, wiring and operation without following guide.

8.3.2.2 Damage caused by fire, flood, abnormal voltage, vibration, etc..

8.3.2.3 Damage caused by the flow meter used in non normal function.

8.3.2.4 Man-made damage.

KLINGER Danmark A/S
Nyager 12-14
DK-2605 Brøndby
Denmark
Phone +45 4364 6611

www.klinger.dk